

# OPERATOR'S MANUAL

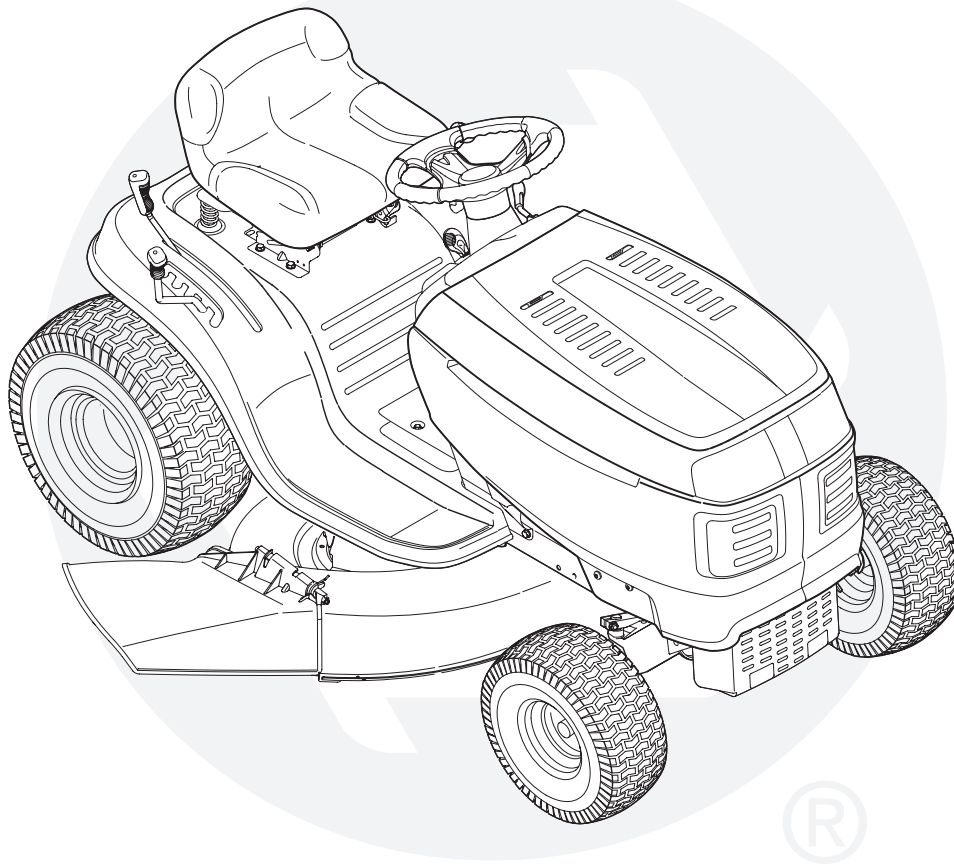

## Transmatic Lawn Tractor — Model Series 77T

### IMPORTANT

#### READ SAFETY RULES AND INSTRUCTIONS CAREFULLY BEFORE OPERATION

**Warning:** This unit is equipped with an internal combustion engine and should not be used on or near any unimproved forest-covered, brush-covered or grass-covered land unless the engine's exhaust system is equipped with a spark arrester meeting applicable local or state laws (if any). If a spark arrester is used, it should be maintained in effective working order by the operator. In the State of California the above is required by law (Section 4442 of the California Public Resources Code). Other states may have similar laws. Federal laws apply on federal lands. A spark arrester for the muffler is available through your nearest engine authorized service dealer or contact the service department, P.O. Box 361131 Cleveland, Ohio 44136-0019.

This Operator's Manual is an important part of your new lawn tractor. It will help you assemble, prepare and maintain the unit for best performance. Please read and understand what it says.

## Table of Contents

Slope Gauge .....	3	Safety Labels .....	25
Safe Operation Practices .....	4	Trouble Shooting .....	26
Setting Up Your Lawn Tractor .....	8	Parts List .....	28
Operating Your Lawn Tractor .....	10	Notes.....	44
Adjusting Your Lawn Tractor.....	16	California Emission Control Warranty .....	47
Maintaining Your Lawn Tractor .....	18	Warranty .....	Back Cover
Off-Season Storage / Attachments .....	24		

## Finding and Recording Model Number

BEFORE YOU START ASSEMBLING YOUR NEW EQUIPMENT, please locate the model plate on the equipment and copy the information to the sample model plate provided to the right. You can locate the model plate by looking beneath the seat. This information will be necessary to use the manufacturer's web site and/or obtain assistance from the Customer Support Department or an authorized service dealer.

Model Number	Serial Number
 www.troybilt.com	TROY-BILT LLC P. O. BOX 361131 CLEVELAND, OH 44136 330-558-7220 866-840-6483

## Customer Support

Please do **NOT** return the unit to the retailer from which it was purchased, without first contacting Customer Support.

If you have difficulty assembling this product or have any questions regarding the controls, operation, or maintenance of this unit, you can seek help from the experts. Choose from the options below:

1. Visit **troybilt.com** for many useful suggestions. Click on Customer Support button and you will get the options reproduced in the screen shot below. Click on the appropriate button and help is immediately available.
2. Phone a **Customer Support Representative** at 1-866-840-6483.
3. The **engine manufacturer** is responsible for all engine-related issues with regard to performance, power-rating, specifications, warranty and service. Please refer to the engine manufacturer's Owner's/Operator's Manual, packed separately with your unit, for more information.



Answers My Stuff Login Help

Products & Services ⓘ All Products Search Text (optional) Search Tips Search

Search by Similar Phrases

Powered by RightNow

Use this page as a guide to determine slopes where you may not operate safely. **Do not operate** your lawn mower on such slopes.

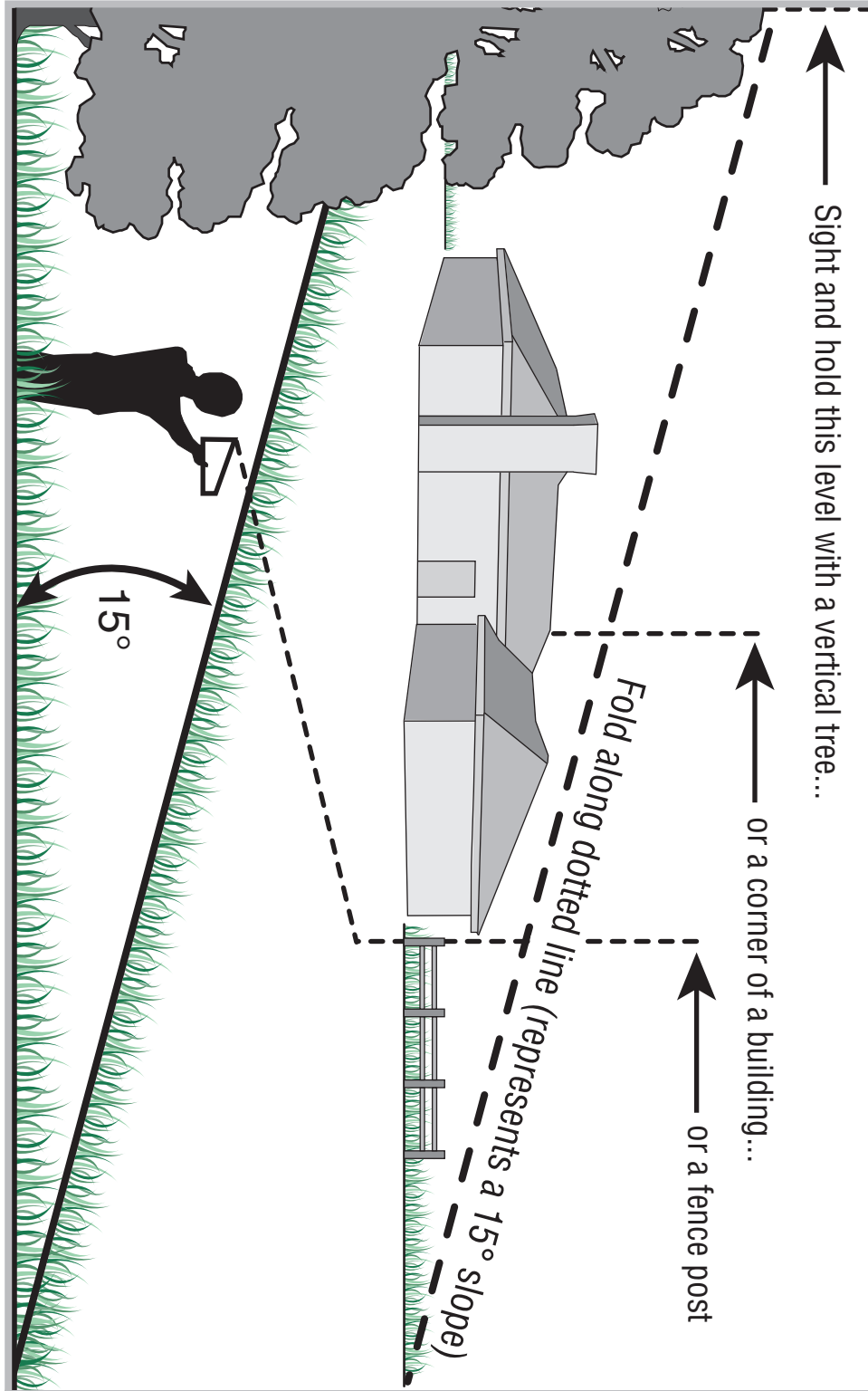

# 1

## Slope Gauge



### WARNING

Do not mow on inclines with a slope in excess of 15 degrees (a rise of approximately 2-1/2 feet every 10 feet). A riding mower could overturn and cause serious injury. If operating a walk-behind mower on such a slope, it is extremely difficult to maintain your footing and you could slip, resulting in serious injury.

Operate RIDING mowers up and down slopes, never across the face of slopes.

Operate WALK-BEHIND mowers across the face of slopes, never up and down slopes.

# 2

## Safe Operation Practices



### WARNING

This symbol points out important safety instructions which, if not followed, could endanger the personal safety and/or property of yourself and others. Read and follow all instructions in this manual before attempting to operate this machine. Failure to comply with these instructions may result in personal injury. When you see this symbol.

#### HEED ITS WARNING

#### Your Responsibility

Restrict the use of this power machine to persons who read, understand and follow the warnings and instructions in this manual



**WARNING:** Engine Exhaust, some of its constituents, and certain vehicle components contain or emit chemicals known to State of California to cause cancer and birth defects or other reproductive harm.

**DANGER:** This machine was built to be operated according to the rules for safe operation in this manual. As with any type of power equipment, carelessness or error on the part of the operator can result in serious injury. This machine is capable of amputating hands and feet and throwing objects. Failure to observe the following safety instructions could result in serious injury or death.

### Children

1. Tragic accidents can occur if the operator is not alert to the presence of children. Children are often attracted to the machine and the mowing activity. They do not understand the dangers. Never assume that children will remain where you last saw them.
  - a. Keep children out of the mowing area and in watchful care of a responsible adult other than the operator.
  - b. Be alert and turn machine off if a child enters the area.
  - c. Before and while backing, look behind and down for small children.
  - d. Never carry children, even with the blade(s) shut off. They may fall off and be seriously injured or interfere with safe machine operation.
  - e. Use extreme care when approaching blind corners, doorways, shrubs, trees or other objects that may block your vision of a child who may run into the machine.
  - f. **To avoid back-over accidents, always disengage the cutting blade(s) before shifting into Reverse. If equipped, the "Reverse Caution Mode" should not be used when children or others are around.**
  - g. Keep children away from hot or running engines. They can suffer burns from a hot muffler.
  - h. Remove key when machine is unattended to prevent unauthorized operation.
2. Never allow children under 14 years old to operate the machine. Children 14 years old and over should read and understand the operation instructions and safety rules in this manual and should be trained and supervised by a parent.

### Operation

#### Safe Handling of Gasoline:

1. **To avoid personal injury or property damage use extreme care in handling gasoline. Gasoline is extremely flammable and the vapors are explosive.** Serious personal injury can occur when gasoline is spilled on yourself or your clothes which can ignite. Wash your skin and change clothes immediately.
  - a. Use only an approved gasoline container.
  - b. Never fill containers inside a vehicle or on a truck or trailer bed with a plastic liner. Always place containers on the ground away from your vehicle before filling.
  - c. When practical, remove gas-powered equipment from the truck or trailer and refuel it on the ground. If this is not possible, then refuel such equipment on a trailer with a portable container, rather than from a gasoline dispenser nozzle.
  - d. Keep the nozzle in contact with the rim of the fuel tank or container opening at all times until fueling is complete. Do not use a nozzle lock-open device.
  - e. Extinguish all cigarettes, cigars, pipes and other sources of ignition.
  - f. Never fuel machine indoors.
  - g. Never remove gas cap or add fuel while the engine is hot or running. Allow engine to cool at least two minutes before refueling.
  - h. Never over fill fuel tank. Fill tank to no more than ½ inch below bottom of filler neck to allow space for fuel expansion.
  - i. Replace gasoline cap and tighten securely.
  - j. If gasoline is spilled, wipe it off the engine and equipment. Move unit to another area. Wait 5 minutes before starting the engine.
  - k. To reduce fire hazards, keep machine free of grass, leaves, or other debris build-up. Clean up oil or fuel spillage and remove any fuel soaked debris.
  - l. Never store the machine or fuel container inside where there is an open flame, spark or pilot light as on a water heater, space heater, furnace, clothes dryer or other gas appliances.
  - m. Allow a machine to cool at least five minutes before storing.

## General Operation:

1. Read, understand, and follow all instructions on the machine and in the manual(s) before attempting to assemble and operate. Keep this manual in a safe place for future and regular reference and for ordering replacement parts.
2. Be familiar with all controls and their proper operation. Know how to stop the machine and disengage them quickly.
3. Never allow children under 14 years old to operate this machine. Children 14 years old and over should read and understand the operation instructions and safety rules in this manual and should be trained and supervised by a parent.
4. Never allow adults to operate this machine without proper instruction.
5. To help avoid blade contact or a thrown object injury, keep bystanders, helpers, children and pets at least 75 feet from the machine while it is in operation. Stop machine if anyone enters the area.
6. Thoroughly inspect the area where the equipment is to be used. Remove all stones, sticks, wire, bones, toys, and other foreign objects which could be picked up and thrown by the blade(s). Thrown objects can cause serious personal injury.
7. Plan your mowing pattern to avoid discharge of material toward roads, sidewalks, bystanders and the like. Also, avoid discharging material against a wall or obstruction which may cause discharged material to ricochet back toward the operator.
8. Always wear safety glasses or safety goggles during operation and while performing an adjustment or repair to protect your eyes. Thrown objects which ricochet can cause serious injury to the eyes.
9. Wear sturdy, rough-soled work shoes and close-fitting slacks and shirts. Loose fitting clothes and jewelry can be caught in movable parts. Never operate this machine in bare feet or sandals.
10. Be aware of the mower and attachment discharge direction and do not point it at anyone. Do not operate the mower without the discharge cover or entire grass catcher in its proper place.
11. Do not put hands or feet near rotating parts or under the cutting deck. Contact with the blade(s) can amputate hands and feet.
12. A missing or damaged discharge cover can cause blade contact or thrown object injuries.
13. Stop the blade(s) when crossing gravel drives, walks, or roads and while not cutting grass.
14. Watch for traffic when operating near or crossing roadways. This machine is not intended for use on any public roadway.
15. Do not operate the machine while under the influence of alcohol or drugs.
16. Mow only in daylight or good artificial light.
17. Never carry passengers.
18. Disengage blade(s) before shifting into reverse. Back up slowly. Always look down and behind before and while backing to avoid a back-over accident.
19. Slow down before turning. Operate the machine smoothly. Avoid erratic operation and excessive speed.
20. Disengage blade(s), set parking brake, stop engine and wait until the blade(s) come to a complete stop before removing grass catcher, emptying grass, unclogging chute, removing any grass or debris, or making any adjustments.
21. Never leave a running machine unattended. Always turn off blade(s), place transmission in neutral, set parking brake, stop engine and remove key before dismounting.
22. Use extra care when loading or unloading the machine into a trailer or truck. This unit should not be driven up or down ramp(s), because the unit could tip over, causing serious personal injury. The unit must be pushed manually on ramp(s) to load or unload properly.
23. Muffler and engine become hot and can cause a burn. Do not touch.
24. Check overhead clearances carefully before driving under low hanging tree branches, wires, door openings etc., where the operator may be struck or pulled from the unit, which could result in serious injury.
25. Disengage all attachment clutches, depress the brake pedal completely and shift into neutral before attempting to start engine.
26. Your machine is designed to cut normal residential grass of a height no more than 10". Do not attempt to mow through unusually tall, dry grass (e.g., pasture) or piles of dry leaves. Dry grass or leaves may contact the engine exhaust and/or build up on the mower deck presenting a potential fire hazard.
27. Use only accessories and attachments approved for this machine by the machine manufacturer. Read, understand and follow all instructions provided with the approved accessory or attachment.
28. Data indicates that operators, age 60 years and above, are involved in a large percentage of riding mower-related injuries. These operators should evaluate their ability to operate the riding mower safely enough to protect themselves and others from serious injury.
29. If situations occur which are not covered in this manual, use care and good judgment. Contact your customer service representative for assistance.

# 2

## Safe Operation Practices



### WARNING

This symbol points out important safety instructions which, if not followed, could endanger the personal safety and/or property of yourself and others. Read and follow all instructions in this manual before attempting to operate this machine. Failure to comply with these instructions may result in personal injury. When you see this symbol.

#### HEED ITS WARNING

#### Your Responsibility

Restrict the use of this power machine to persons who read, understand and follow the warnings and instructions in this manual

# 2

## Safe Operation Practices



This symbol points out important safety instructions which, if not followed, could endanger the personal safety and/or property of yourself and others. Read and follow all instructions in this manual before attempting to operate this machine. Failure to comply with these instructions may result in personal injury. When you see this symbol.

**HEED ITS WARNING**

### Your Responsibility

Restrict the use of this power machine to persons who read, understand and follow the warnings and instructions in this manual

### Slope Operation:

Slopes are a major factor related to loss of control and tip-over accidents which can result in severe injury or death. All slopes require extra caution. If you cannot back up the slope or if you feel uneasy on it, do not mow it.

For your safety, use the slope gauge included as part of this manual to measure slopes before operating this unit on a sloped or hilly area. If the slope is greater than 15 degrees as shown on the slope gauge, do not operate this unit on that area or serious injury could result.

#### Do:

1. Mow up and down slopes, not across. Exercise extreme caution when changing direction on slopes.
2. Watch for holes, ruts, bumps, rocks, or other hidden objects. Uneven terrain could overturn the machine. Tall grass can hide obstacles.
3. Use slow speed. Choose a low enough speed setting so that you will not have to stop or shift while on the slope. Tires may lose traction on slopes even though the brakes are functioning properly. Always keep machine in gear when going down slopes to take advantage of engine braking action.
4. Follow the manufacturer's recommendations for wheel weights or counterweights to improve stability.
5. Use extra care with grass catchers or other attachments. These can change the stability of the machine.
6. Keep all movement on the slopes slow and gradual. Do not make sudden changes in speed or direction. Rapid engagement or braking could cause the front of the machine to lift and rapidly flip over backwards which could cause serious injury.
7. Avoid starting or stopping on a slope. If tires lose traction, disengage the blade(s) and proceed slowly straight down the slope.

### Do Not:

1. Do not turn on slopes unless necessary; then, turn slowly and gradually downhill, if possible.
2. Do not mow near drop-offs, ditches or embankments. The mower could suddenly turn over if a wheel is over the edge of a cliff, ditch, or if an edge caves in.
3. Do not try to stabilize the machine by putting your foot on the ground.
4. Do not use a grass catcher on steep slopes.
5. Do not mow on wet grass. Reduced traction could cause sliding.
6. Do not shift to neutral and coast downhill. Over-speeding may cause the operator to lose control of the machine resulting in serious injury or death.
7. Do not tow heavy pull behind attachments (e.g. loaded dump cart, lawn roller, etc.) on slopes greater than 5 degrees. When going down hill, the extra weight tends to push the tractor and may cause you to lose control. (e.g. tractor may speed up, braking and steering ability are reduced, attachment may jack-knife and cause tractor to overturn).

### Towing:

1. Tow only with a machine that has a hitch designed for towing. Do not attach towed equipment except at the hitch point.
2. Follow the manufacturer's recommendation for weight limits for towed equipment and towing on slopes.
3. Never allow children or others in or on towed equipment.
4. On slopes, the weight of the towed equipment may cause loss of traction and loss of control.
5. Travel slowly and allow extra distance to stop.
6. Do not shift to neutral and coast downhill.

## Service

1. Never run an engine indoors or in a poorly ventilated area. Engine exhaust contains carbon monoxide, an odorless, and deadly gas.
2. Before cleaning, repairing, or inspecting, make certain the blade(s) and all moving parts have stopped. Disconnect the spark plug wire and ground against the engine to prevent unintended starting.
3. Periodically check to make sure the blades come to complete stop within approximately (5) five seconds after operating the blade disengagement control. If the blades do not stop within the this time frame, your unit should be serviced professionally by an authorized MTD Service Dealer.
4. Check brake operation frequently as it is subjected to wear during normal operation. Adjust and service as required.
5. Check the blade(s) and engine mounting bolts at frequent intervals for proper tightness. Also, visually inspect blade(s) for damage (e.g., excessive wear, bent, cracked). Replace the blade(s) with the original equipment manufacturer's (O.E.M.) blade(s) only, listed in this manual. "Use of parts which do not meet the original equipment specifications may lead to improper performance and compromise safety!"
6. Mower blades are sharp. Wrap the blade or wear gloves, and use extra caution when servicing them.
7. Keep all nuts, bolts, and screws tight to be sure the equipment is in safe working condition.
8. Never tamper with the safety interlock system or other safety devices. Check their proper operation regularly.
9. After striking a foreign object, stop the engine, disconnect the spark plug wire(s) and ground against the engine. Thoroughly inspect the machine for any damage. Repair the damage before starting and operating.
10. Never attempt to make adjustments or repairs to the machine while the engine is running.
11. Grass catcher components and the discharge cover are subject to wear and damage which could expose moving parts or allow objects to be thrown. For safety protection, frequently check components and replace immediately with original equipment manufacturer's (O.E.M.) parts only, listed in this manual. "Use of parts which do not meet the original equipment specifications may lead to improper performance and compromise safety!"
12. Do not change the engine governor settings or over-speed the engine. The governor controls the maximum safe operating speed of the engine.
13. Maintain or replace safety and instruction labels, as necessary.
14. Observe proper disposal laws and regulations for gas, oil, etc. to protect the environment.

# 2

## Safe Operation Practices



This symbol points out important safety instructions which, if not followed, could endanger the personal safety and/or property of yourself and others. Read and follow all instructions in this manual before attempting to operate this machine. Failure to comply with these instructions may result in personal injury. When you see this symbol.

**HEED ITS WARNING**

### Your Responsibility

Restrict the use of this power machine to persons who read, understand and follow the warnings and instructions in this manual

# 3

## Setting Up Your Lawn Tractor



### WARNING

Use extreme care when handling gasoline. Gasoline is extremely flammable and the vapors are explosive. Never fuel machine indoors or while the engine is hot or running. Extinguish cigarettes, cigars, pipes, and other sources of ignition. Make sure the riding mower's engine is off, remove the ignition key, and set the parking brake before removing the shipping brace.

The shipping brace, used for packaging purposes only, must be removed and discarded before operating your riding mower.

The mowing deck is capable of throwing objects. Failure to operate the riding mower without the discharge cover in the proper operating position could result in serious personal injury and/or property damage.

## Attaching the Battery Cables

**NOTE:** This unit may have been shipped with the battery cables already connected. If not, follow the instructions below for attaching the battery cables.

**NOTE:** The positive battery terminal is marked Pos. (+). The negative battery terminal is marked Neg. (-).

- The positive cable (heavy red wire) is secured to the positive battery terminal (+) with a hex bolt and hex nut at the factory. Make certain that the rubber boot covers the terminal to help protect it from corrosion.
- Remove the hex bolt and hex nut from the negative cable.
- Remove the black plastic cover, if present, from the negative battery terminal and attach the negative cable (heavy black wire) to the negative battery terminal (-) with the bolt and nut.
- Make certain the hold-down strap is in position over the battery, securing it in place. See Figure 1.

**NOTE:** If the battery is put into service after the date shown on top of battery, charge the battery as instructed on page 20 of this manual prior to operating the tractor.

## Gas and Oil Fill-up

The gasoline tank is located under the hood and has a capacity of 1-1/2 gallons. Do not overfill.



**WARNING:** Use extreme care when handling gasoline. Gasoline is extremely flammable and the vapors are explosive. Never fuel machine indoors or while the engine is hot or running. Extinguish cigarettes, cigars, pipes, and other sources of ignition.

Service the engine with gasoline and oil as instructed in the separate Engine Operator/Owner's Manual packed with your tractor. Read instructions carefully.

**IMPORTANT:** Your tractor is shipped with motor oil in the engine. However, you MUST check the oil level before operating. Be careful not to overfill.

## Shipping Brace Removal



**WARNING:** Make sure the riding mower's engine is off, remove the ignition key, and set the parking brake before removing the shipping brace.

- Locate the shipping brace, if present, and accompanying warning tag found on the right side of the mower, between the discharge chute and the cutting deck. See Figure 2.

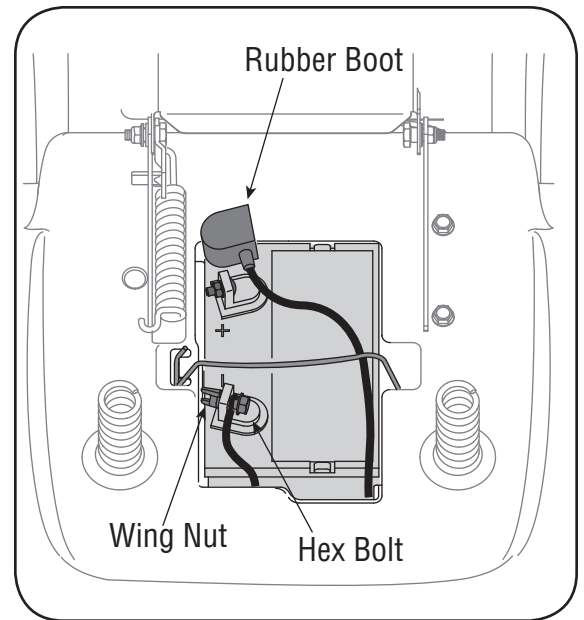

Figure 1

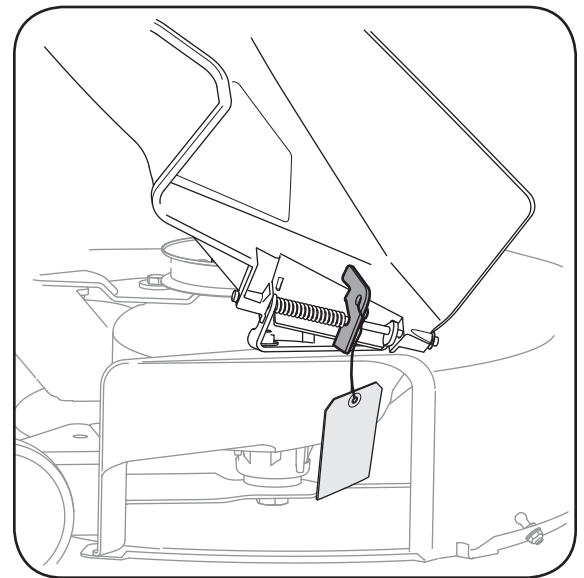

Figure 2

- While holding the discharge chute with your left hand, remove the shipping brace with your right hand by grasping it between your thumb and index finger and rotating it clockwise.



**WARNING:** The shipping brace, used for packaging purposes only, must be removed and discarded before operating your riding mower.



**WARNING:** The mowing deck is capable of throwing objects. Failure to operate the riding mower without the discharge cover in the proper operating position could result in serious personal injury and/or property damage.



## Attaching The Steering Wheel

If the steering wheel for your tractor did not come attached, the hardware for attaching it has been packed within the steering wheel, beneath the steering wheel cap. Carefully pry off the steering wheel cap and remove the hardware.

1. **With the wheels of the tractor pointing straight forward**, place the steering wheel over the steering shaft.
2. Place the washer (with the cupped side down) over the steering shaft and secure with the hex bolt. See Figure 3.
3. Place the steering wheel cap over the center of the steering wheel and push downward until it “clicks” into place.

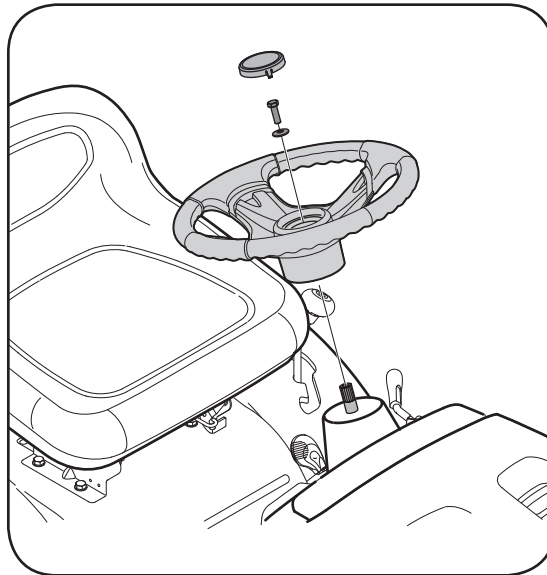

Figure 3

## Attaching The Seat

If the seat for your tractor did not come attached, follow the instructions below to attach it.

**NOTE:** For shipping reasons, seats are either fastened to the tractor seat's pivot bracket with a plastic tie, or mounted backward to the pivot bracket. In either case, free the seat from its shipping position and remove the two knobs from the bottom of seat before proceeding with applicable instructions below.



**WARNING:** Before operating this machine, make sure the seat is engaged in the seat stop, stand behind the machine and pull back on seat until fully engaged into stop.

### Knob Adjustment Seat

1. Position the shoulder screws (found on the base of the seat) inside the slot openings in the seat pivot bracket. Figure 4.
2. Slide the seat slightly rearward in the seat pivot bracket, lining up the rear slots in the pivot bracket with the remaining two holes in the seat's base.
3. Select desired position for the seat, and secure with the two knobs removed earlier. See Figure 4.

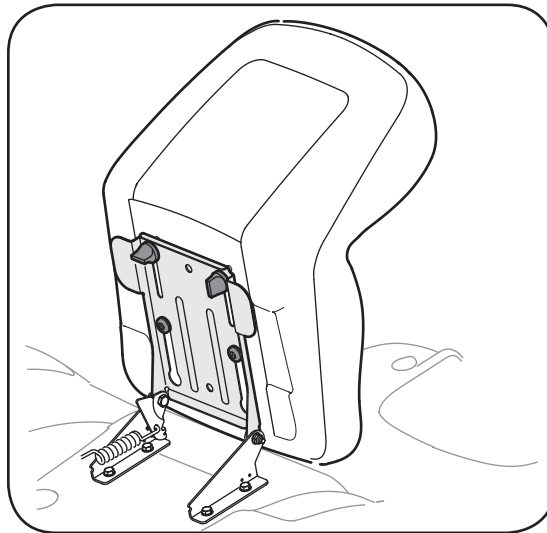

Figure 4

### Tire Pressure



**WARNING:** Maximum tire pressure under any circumstances is 30 psi. Equal tire pressure should be maintained at all times.

The tires on your unit may be over-inflated for shipping purposes. Reduce the tire pressure before operating the tractor. Recommended operating tire pressure is approximately 10 p.s.i for the rear tires & 14 p.s.i. for the front tires. Check sidewall of tire for maximum p.s.i.

# 3

## Setting Up Your Lawn Tractor



### WARNING

Before operating this machine, make sure the seat is engaged in the seat stop, stand behind the machine and pull back on seat until fully engaged into stop.

Maximum tire pressure under any circumstances is 30 psi. Equal tire pressure should be maintained at all times.

# 4

## Operating Your Lawn Tractor



NOTE: Any reference in this manual to the RIGHT or LEFT side of the tractor is observed from operator's position.

## Know Your Lawn Tractor

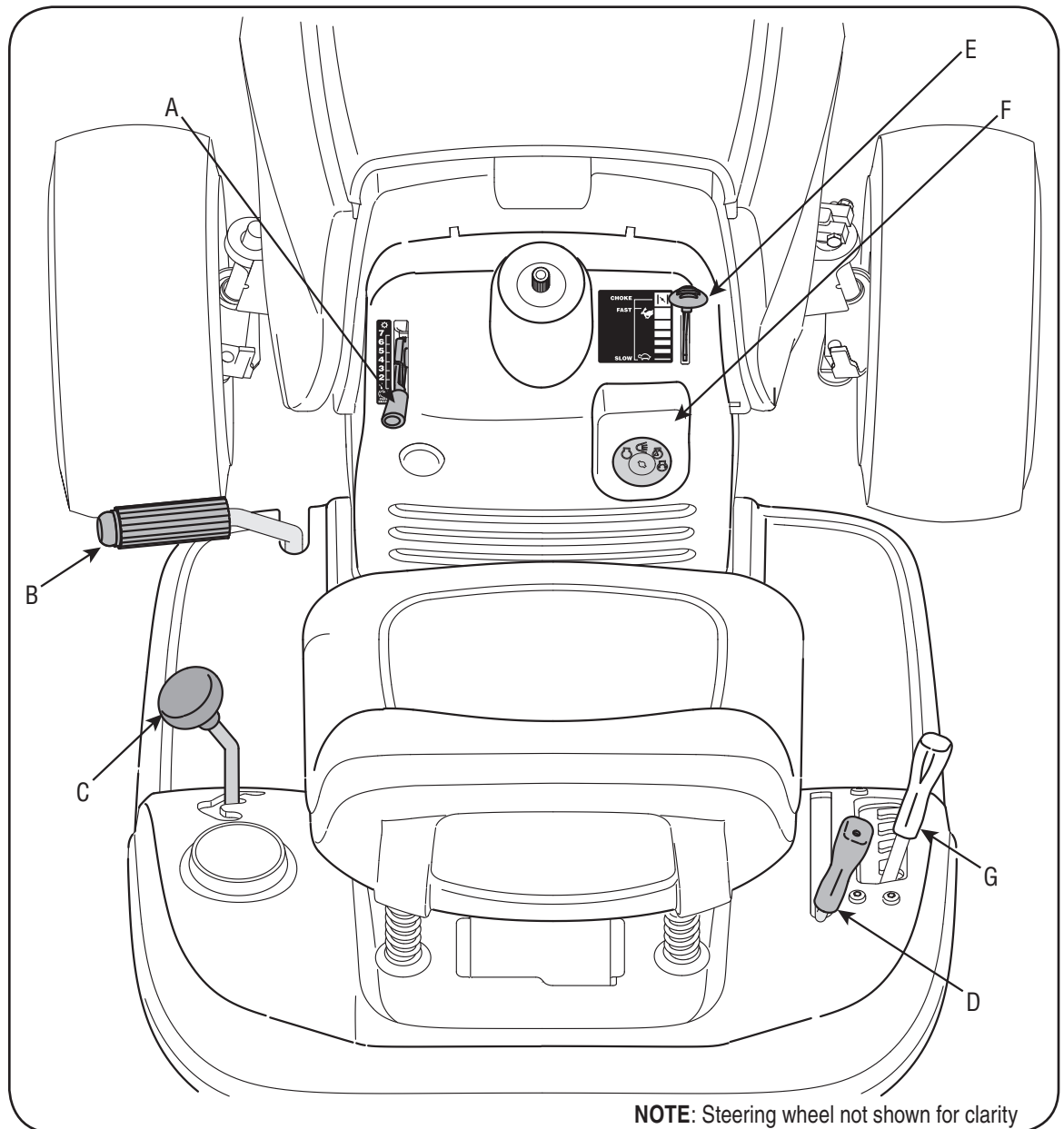

NOTE: Steering wheel not shown for clarity

Figure 5

A	Speed Control Lever/ Parking Brake	E	Throttle /Choke Control Lever
B	Clutch-Brake Pedal	F	Ignition Switch
C	Shift Lever	G	Deck Lift Lever
D	PTO (Blade Engage) Lever		

### Throttle / Choke Control

The throttle control lever is located on the right side of the tractor's dash panel. This lever controls the speed of the engine, as well as the choke when it is pushed all the way forward. When set in a given position, the throttle will maintain a uniform engine speed. See Fig. 5.

**IMPORTANT:** When operating the tractor with the cutting deck engaged, be certain that the throttle lever is **always** in the FAST (rabbit) position.

Moving the throttle lever all the way forward activates the engine's choke control. Activating the choke control closes the choke plate on the carburetor and aids in starting the engine. Refer to **Starting The Engine** on page 12 of this manual for detailed starting instructions.

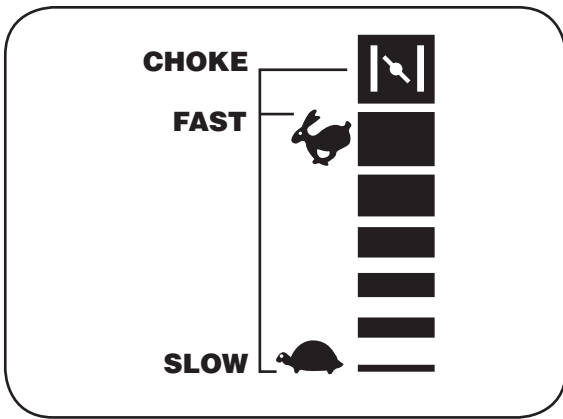

Figure 6

## Ignition Switch

The ignition switch is activated to start the engine. Insert key into the ignition switch and turn clockwise to the START position. Release the key into the ON position once engine has fired. See Figure 7.

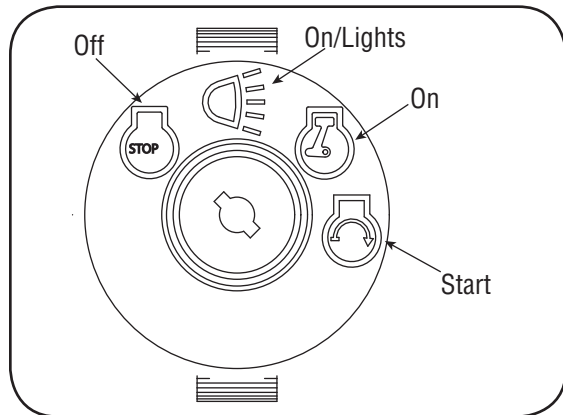

Figure 7



**WARNING:** Never leave a running machine unattended. Always disengage PTO, move shift lever into neutral position, set parking brake, stop engine and remove key to prevent unintended starting.

**IMPORTANT:** Prior to operating the tractor, refer to both **Safety Interlock Switches** and **Starting The Engine** on page 12 of this manual for detailed instructions regarding the Ignition Switch Module.

## Deck Lift Lever

Found on your tractor's right fender, the deck lift lever is used to change the height of the cutting deck. To use, move the lever to the left, then place in the notch best suited for your application.

## Parking Brake

To set the parking brake, fully depress the clutch-brake pedal. Move the speed control lever all the way down and into the parking brake position. Release the clutch-brake pedal to allow the parking brake to engage.

To release the parking brake, depress the clutch-brake pedal and move the speed control lever out of the notches to the desired position. Release the speed control lever and the clutch-brake pedal.

**NOTE:** The parking brake must be set if the operator leaves the seat with the engine running or the engine will automatically shut off.

## Clutch-Brake Pedal

The clutch-brake pedal is located on the left side of the lawn tractor, along the running board. Depress the clutch-brake pedal part way down when slowing the tractor by changing speeds (Refer to Speed Control Lever). Depress the pedal all the way down to engage the disc brake and bring the tractor to a complete stop.

**NOTE:** The pedal must be depressed to start the engine. Refer to Safety Interlock Switches on page 12.

## Shift Lever

The shift lever is located on the left side of the fender and has three positions, FORWARD, NEUTRAL and REVERSE. The brake pedal must be depressed and the tractor must not be in motion when the moving shift lever. See Figure 8.

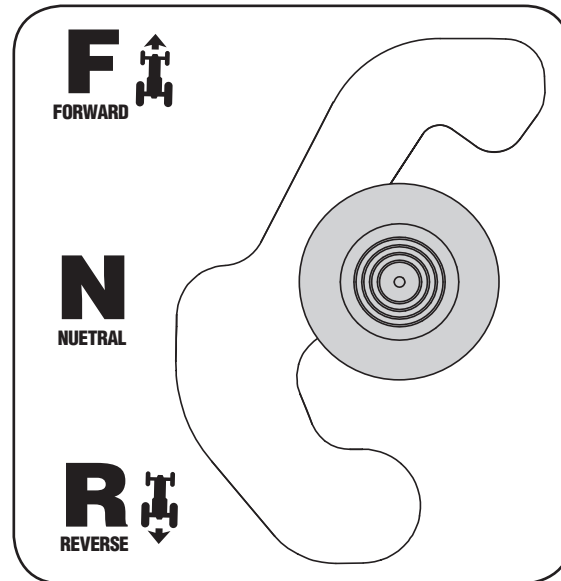

Figure 8

**IMPORTANT:** Never force the shift lever. Doing so may result in serious damage to the tractor's transmission.

## Speed Control Lever

The speed control lever, located on the left side of the tractor's dash console, allows you to regulate the ground speed of the lawn tractor. To use, depress the clutch-brake pedal and move the lever out of the parking brake notch and forward to increase the tractor's ground speed. When a desired speed has been reached, release the lever into an appropriate notch to maintain that speed.

To slow the tractor's ground speed, depress the clutch-brake pedal and move the speed control lever rearward and release it into a notch.

4

# Operating Your Lawn Tractor



## WARNING

Never leave a running machine unattended. Always disengage PTO, move shift lever into neutral position, set parking brake, stop engine and remove key to prevent unintended starting.



## IMPORTANT

Prior to operating the tractor, refer to both the **Safety Interlock Switches** and **Starting The Engine** on page 12 of this manual for detailed instructions regarding the Ignition Switch Module.

# 4

## Operating Your Lawn Tractor



### WARNING

Do not operate the tractor if the interlock system is malfunctioning. This system was designed for your safety and protection.

Keep hands and feet away from the discharge opening of the cutting deck.

Do not operate the tractor if the interlock system is malfunctioning. This system was designed for your safety and protection.

If you strike a foreign object, stop the engine, disconnect the spark plug wire(s) and ground against the engine. Thoroughly inspect the machine for any damage. Repair the damage before restarting and operating.

### PTO (Blade Engage) Lever

Found on the tractor's right fender, the PTO (blade engage) lever is used to engage power to the cutting deck or other (separately available) attachments. To operate, move the lever all the way forward. Moving the lever all the way rearward into the PTO OFF position disengages power to the cutting deck/ attachment.

**NOTE:** The PTO (blade engage) lever must be in the disengaged (PTO OFF) position when starting the engine.

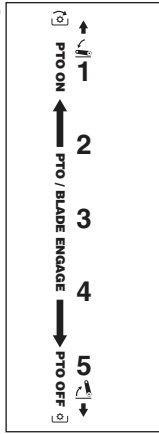

### Safety Interlock Switches

This tractor is equipped with a safety interlock system for the protection of the operator. If the interlock system should ever malfunction, do not operate the tractor. Contact an authorized Troybilt service dealer.

- The safety interlock system prevents the engine from cranking or starting unless the parking brake is engaged, and the PTO (Blade Engage) lever is in the disengaged (OFF) position.
- The engine will automatically shut off if the operator leaves the seat before engaging the parking brake.
- The engine will automatically shut off if the operator leaves the tractor's seat with the PTO (Blade Engage) lever in the engaged (ON) position, regardless of whether the parking brake is engaged.
- The engine will automatically shut off if the operator engages the PTO with the parking brake ON.
- The engine will automatically shut off if the PTO (Blade Engage) lever is moved into the engaged (ON) position with the shift lever in Reverse.



**WARNING: Do not operate the tractor if the interlock system is malfunctioning. This system was designed for your safety and protection.**

### Engaging the Parking Brake

To engage the parking brake:

1. Fully depress the clutch-brake pedal and hold it down with your foot.
2. Move the speed control lever all the way down and into the parking brake position.
3. Release the clutch-brake pedal to allow the parking brake to engage.

To release the parking brake:

1. Depress the clutch-brake pedal and move the speed control lever out of the parking brake position and into a desired speed.

### Setting the Cutting Height

1. Select the height position of the cutting deck by placing the deck lift lever in any of the six different cutting height notches on the right side of the fender.



**WARNING: Keep hands and feet away from the discharge opening of the cutting deck.**

Refer to **Leveling the Deck** on page 16 of this manual for more detailed instructions regarding various deck adjustments.

### Starting the Engine



**WARNING: Do not operate the tractor if the interlock system is malfunctioning. This system was designed for your safety and protection.**

**NOTE:** Refer to the **TRACTOR SET-UP** on page 8 of this manual for Gasoline and Oil fill-up instructions.

1. Insert the tractor key into the ignition switch.
2. Place the PTO (Blade Engage) lever in the disengaged (OFF) position.
3. Engage the tractor's parking brake.
4. Activate the choke control.
5. Turn the ignition key clockwise to the START position. After the engine starts, release the key. It will return to the ON position.

**IMPORTANT:** Do NOT hold the key in the START position for longer than ten seconds at a time. Doing so may cause damage to your engine's electric starter.

6. After the engine starts, deactivate the choke control and place the throttle control in the FAST position.

**NOTE:** Do NOT leave the choke control on while operating the tractor. Doing so will result in a "rich" fuel mixture and cause the engine to run poorly.

### Stopping the Engine



**WARNING: If you strike a foreign object, stop the engine, disconnect the spark plug wire(s) and ground against the engine. Thoroughly inspect the machine for any damage. Repair the damage before restarting and operating.**

1. If the blades are engaged, place the PTO (Blade Engage) lever in the disengaged (OFF) position.
2. Turn the ignition key counterclockwise to the STOP position.
3. Remove the key from the ignition switch to prevent unintended starting.

## Driving The Tractor



**WARNING: Avoid sudden starts, excessive speed and sudden stops.**



**WARNING: Do not leave the seat of the tractor without first placing the PTO (Blade Engage) lever in the disengaged (OFF) position, depressing the brake pedal and engaging the parking brake. If leaving the tractor unattended, also turn the ignition key off and remove the key.**



**WARNING: Always look down and behind before and while backing up to avoid a back-over accident.**

1. Depress the brake pedal to release the parking brake and let the pedal up.
2. Move the throttle lever into the FAST (rabbit) position.
3. Place the shift lever in either the FORWARD or REVERSE position.

**IMPORTANT:** Do NOT use the shift lever to change the direction of travel when the tractor is in motion. Always use the brake pedal to bring the tractor to a complete stop before shifting.

4. Release the parking brake by depressing the clutch-brake pedal and positioning the speed control lever in desired position.

**IMPORTANT:** First-time operators should use speed positions 1 or 2. Become completely familiar with the tractor's operation and controls before operating the tractor in higher speed positions.

5. Release clutch-brake pedal slowly to put unit into motion.
6. The lawn tractor is brought to a stop by depressing the clutch-brake pedal.

**NOTE:** When operating the unit initially, there will be little difference between the highest two speeds until after the belts have seated themselves into the pulleys during the break-in period.



**WARNING: Before leaving the operator's position for any reason, disengage the blades, place the shift lever in neutral, engage the parking brake, shut engine off and remove the key.**

**IMPORTANT:** When stopping the tractor for any reason while on a grass surface, always:

1. Place the shift lever in neutral,
2. Engage the parking brake,
3. Shut engine off and remove the key.

Doing so will minimize the possibility of having your lawn "browned" by hot exhaust from your tractor's running engine.

**If unit stalls** with speed control in high speed, or if unit will not operate with speed control lever in a low speed position, proceed as follows:

1. Place shift lever in NEUTRAL.
2. Restart engine.
3. Place speed control lever in highest speed position.
4. Release clutch-brake pedal fully.
5. Depress clutch-brake pedal.
6. Place speed control lever in desired position.
7. Place shift lever in either FORWARD or REVERSE, and follow normal operating procedures.

## Driving On Slopes

Refer to the SLOPE GAUGE on page 3 to help determine slopes where you may operate the tractor safely.



**WARNING: Do not mow on inclines with a slope in excess of 15 degrees (a rise of approximately 2-1/2 feet every 10 feet). The tractor could overturn and cause serious injury.**

- Mow up and down slopes, NEVER across.
- Exercise extreme caution when changing direction on slopes.
- Watch for holes, ruts, bumps, rocks, or other hidden objects. Uneven terrain could overturn the machine. Tall grass can hide obstacles.
- Avoid turns when driving on a slope. If a turn must be made, turn down the slope. Turning up a slope greatly increases the chance of a roll over.
- Avoid stopping when driving up a slope. If it is necessary to stop while driving up a slope, start up smoothly and carefully to reduce the possibility of flipping the tractor over backward.

# 4

## Operating Your Lawn Tractor



### WARNING

**Avoid sudden starts, excessive speed and sudden stops.**

**Do not leave the seat of the tractor without first placing the PTO (Blade Engage) lever in the disengaged (OFF) position, depressing the brake pedal and engaging the parking brake. If leaving the tractor unattended, also turn the ignition key off and remove the key.**

**Always look down and behind before and while backing up to avoid a back-over accident.**

**Before leaving the operator's position for any reason, disengage the blades, place the shift lever in neutral, engage the parking brake, shut engine off and remove the key.**

# 4

## Operating Your Lawn Tractor



### WARNING

To help avoid blade contact or a thrown object injury, keep bystanders, helpers, children and pets at least 75 feet from the machine while it is in operation. Stop machine if anyone enters the area.

Plan your mowing pattern to avoid discharge of materials toward roads, sidewalks, bystanders and the like. Also, avoid discharging material against a wall or obstruction which may cause discharged material to ricochet back toward the operator.

### Engaging the Blades

Engaging the PTO (Blade Engage) transfers power to the cutting deck or other (separately available) attachments. To engage the blades, proceed as follows:

1. Move the throttle control lever to the FAST (rabbit) position.
2. Grasp the PTO (Blade Engage) lever and pivot it all the way forward into the engaged (ON) position.
3. Keep the throttle lever in the FAST (rabbit) position for the most efficient use of the cutting deck or other (separately available) attachments

**IMPORTANT:** The PTO (Blade Engage) lever must be in the disengaged (OFF) position when starting the engine, when traveling in reverse, and if the operator leaves the seat. Refer to Safety Interlock Switches on page 12.

### Using the Deck Lift Lever

To raise the cutting deck, move the deck lift lever to the left, then place it in the notch best suited for your application. Refer to Setting The Cutting Height earlier in this section.

### Mowing



**WARNING: To help avoid blade contact or a thrown object injury, keep bystanders, helpers, children and pets at least 75 feet from the machine while it is in operation. Stop machine if anyone enters the area.**

The following information will be helpful when using the cutting deck with your tractor:



**WARNING: Plan your mowing pattern to avoid discharge of materials toward roads, sidewalks, bystanders and the like. Also, avoid discharging material against a wall or obstruction which may cause discharged material to ricochet back toward the operator.**

- Do not mow at high ground speed, especially if a mulch kit or grass collector is installed.
- For best results it is recommended that the first two laps be cut with the discharge thrown towards the center. After the first two laps, reverse the direction to throw the discharge to the outside for the balance of cutting. This will give a better appearance to the lawn.
- Do not cut the grass too short. Short grass invites weed growth and yellows quickly in dry weather.



## WARNING

### AVOID SERIOUS INJURY OR DEATH

- GO UP AND DOWN SLOPES, NOT ACROSS.
- AVOID SUDDEN TURNS.
- DO NOT OPERATE THE UNIT WHERE IT COULD SLIP OR TIP.
- IF MACHINE STOPS GOING UPHILL, STOP BLADE(S) AND BACK DOWNHILL SLOWLY.
- DO NOT MOW WHEN CHILDREN OR OTHERS ARE AROUND.
- NEVER CARRY CHILDREN, EVEN WITH BLADES OFF.
- LOOK DOWN AND BEHIND BEFORE AND WHILE BACKING.
- KEEP SAFETY DEVICES (GUARDS, SHIELDS, AND SWITCHES) IN PLACE AND WORKING.
- REMOVE OBJECTS THAT COULD BE THROWN BY THE BLADE(S).
- KNOW LOCATION AND FUNCTION OF ALL CONTROLS.
- BE SURE BLADE(S) AND ENGINE ARE STOPPED BEFORE PLACING HANDS OR FEET NEAR BLADE(S).
- BEFORE LEAVING OPERATOR'S POSITION, DISENGAGE BLADE(S), PLACE THE SHIFT LEVER IN NEUTRAL, ENGAGE BRAKE LOCK, SHUT ENGINE OFF AND REMOVE KEY.

### READ OPERATOR'S MANUAL

- Mowing should always be done with the engine at full throttle.
- Under heavier conditions it may be necessary to go back over the cut area a second time to get a clean cut.
- Do NOT attempt to mow heavy brush and weeds and extremely tall grass. Your tractor is designed to mow lawns, NOT clear brush.
- Keep the blades sharp and replace the blades when worn. Refer to **Cutting Blades** on page 21 of this manual for proper blade sharpening instructions.

## Mulching (If Equipped)

A mulch kit is sold separately and incorporates special blades that incorporate a process of recirculating grass clippings repeatedly beneath the cutting deck. The ultra-fine clippings are then forced back into the lawn where they act as a natural fertilizer.

Observe the following points for the best results when mulching:

- Never attempt to mulch if the lawn is damp. Wet grass tends to stick to the underside of the cutting deck preventing proper mulching of the clippings.
- Do NOT attempt to mulch more than 1/3 the total height of the grass or approximately 1-1/2 inches. Doing so will cause the clippings to clump up beneath the deck and not be mulched effectively.
- Maintain a slow ground speed to allow the grass clippings more time to effectively be mulched.
- Always position the throttle control lever in the FAST (rabbit) position and allow it to remain there while mowing. Failing to keep the engine at full throttle places strain on the tractor's engine and does not allow the blades to properly mulch grass.

**NOTE:** It is not necessary to remove the discharge chute to operate the mower with the mulch kit installed.

To operate the cutting deck without mulching, simply remove the mulch plug by unthreading the plastic wing nut which fastens it to the cutting deck. This will allow the clippings to discharge out the side. See Figure 9.

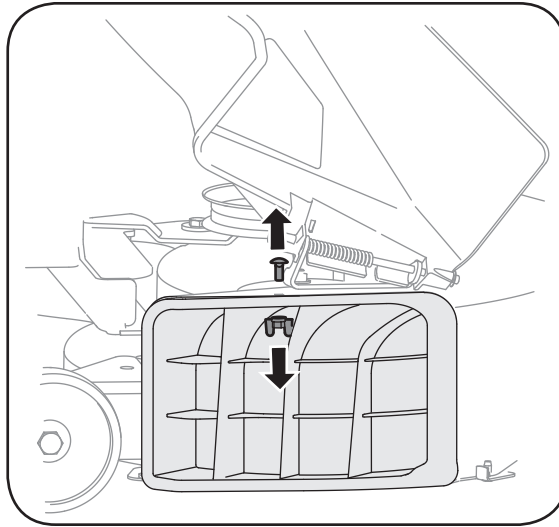

Figure 9

## Headlights

- On some models, the lamps are ON whenever the tractor's engine is running. On other models, the lamps are ON whenever the ignition key is moved out of the STOP position.
- On all models, the lamps turn OFF when the ignition key is moved to the STOP position.

# 4

## Operating Your Lawn Tractor



**NOTE:** It is not necessary to remove the discharge chute to operate the mower with the mulch kit installed.

# 5

## Adjusting Your Lawn Tractor



### WARNING

Never attempt to make any adjustments while the engine is running, except where specified in the operator's manual.

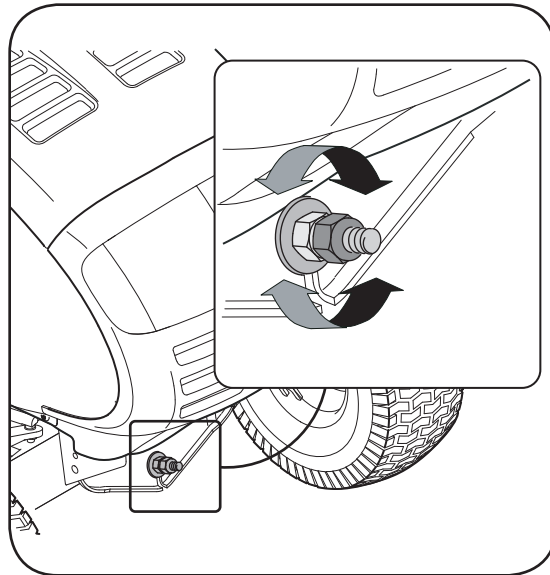

Figure 10

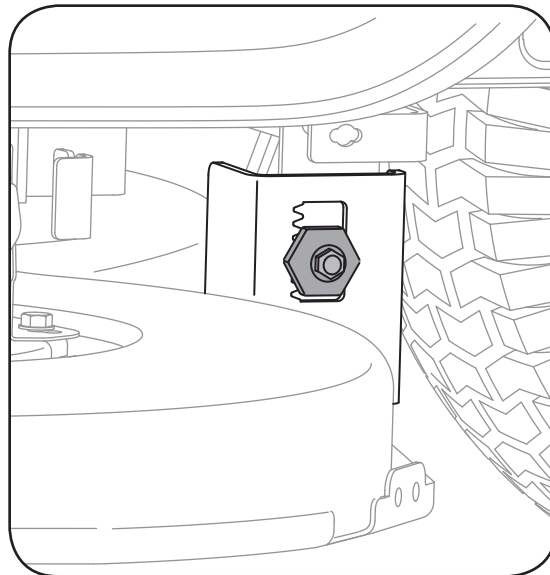

Figure 11



**WARNING: Never attempt to make any adjustments while the engine is running, except where specified in the operator's manual.**

### Leveling the Deck

**NOTE:** Check the tractor's tire pressure before performing any deck leveling adjustments. Refer to **Tires** on page 20 for information regarding tire pressure.

#### Front To Rear

The front of the cutting deck is supported by a stabilizer bar that can be adjusted to level the deck from front to rear. The front of the deck should be between 1/4-inch and

3/8-inch lower than the rear of the deck. Adjust if necessary as follows:

1. With the tractor parked on a firm, level surface, place the deck lift lever in the top notch (highest position) and rotate the blade nearest the discharge chute so that it is parallel with the tractor.
2. Measure the distance from the front of the blade tip to the ground and the rear of the blade tip to the ground. The first measurement taken should be between 1/4" and 3/8" less than the second measurement. Determine the approximate distance necessary for proper adjustment and proceed, if necessary, to the next step.
3. Locate the jam nut and lock nut on the front side of the stabilizer bracket. See Figure 10. After loosening the jam nut:

Tighten the lock nut to raise the front of the deck;

Loosen the lock nut to lower the front of the deck.

4. Retighten the jam nut loosened earlier when proper adjustment is achieved.

#### Side to Side

If the cutting deck appears to be mowing unevenly, a side to side adjustment can be performed. Adjust if necessary as follows:

1. With the tractor parked on a firm, level surface, place the deck lift lever in the top notch (highest position) and rotate both blades so that they are perpendicular with the tractor.
2. Measure the distance from the outside of the left blade tip to the ground and the distance from the outside of the right blade tip to the ground. Both measurements taken should be equal. If they're not, proceed to the next step.
3. Loosen, but do NOT remove, the hex cap screw on the left deck hanger bracket. See Figure 11.
4. Balance the deck by using a wrench to turn the adjustment gear (found immediately behind the hex cap screw just loosened) clockwise/up or counter-clockwise/down. The deck is properly balanced when both blade tip measurements taken earlier are equal.
5. Retighten the hex cap screw on the left deck hanger bracket when proper adjustment is achieved.



## Parking Brake Adjustment



**WARNING:** Never attempt to adjust the brakes while the engine is running. Always disengage PTO, move shift lever into neutral position, stop engine and remove key to prevent unintended starting.

If the tractor does not come to a complete stop when the brake pedal is completely depressed, or if the tractor's rear wheels can roll with the parking brake applied, the brake is in need of adjustment. The brake disc can be found on the right side of the transmission in the rear of the tractor. Adjust if necessary as follows:

1. Looking at the transmission from the right side of the tractor, locate the compression spring and brake disc. See Figure 12.
2. Loosen, but do NOT remove, the hex nut found on the right side of the brake assembly. See Figure 12.
3. Using a feeler gauge, set the gap between the brake disc and the brake puck at .011".
4. Re-tighten the hex nut loosened earlier.

## Seat Adjustment



**WARNING:** Before operating this machine, make sure the seat is engaged in the seat stop, stand behind the machine and pull back on seat until fully engaged into stop.

### Knob Adjustment Seat

To adjust the position of the seat on models so equipped, loosen the two knobs on the bottom of the seat. See Figure 13. Slide the seat forward or backward as desired. Retighten the two knobs.

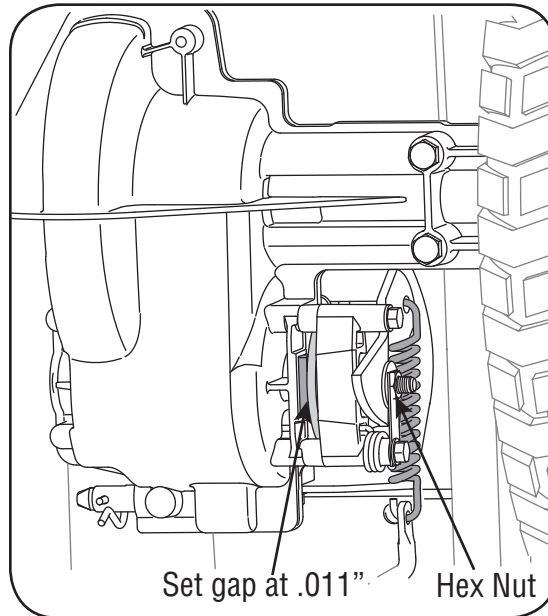

Figure 12

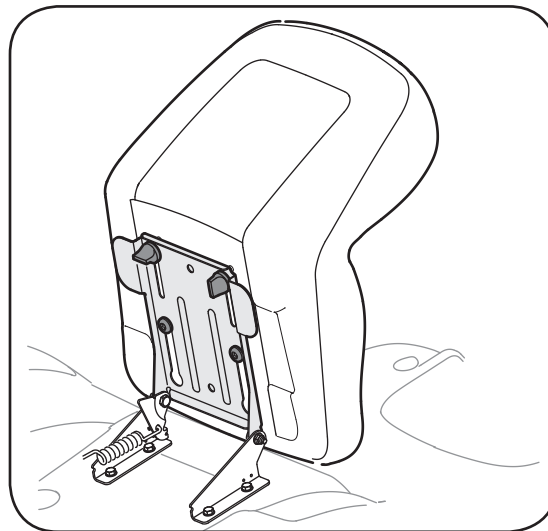

Figure 13

# 5

## Adjusting Your Lawn Tractor



### WARNING

Never attempt to adjust the brakes while the engine is running. Always disengage PTO, move shift lever into neutral position, stop engine and remove key to prevent unintended starting.

Before operating this machine, make sure the seat is engaged in the seat stop, stand behind the machine and pull back on seat until fully engaged into stop.

# 6

## Maintaining Your Lawn Tractor



### WARNING

Before performing any maintenance or repairs, disengage PTO, move shift lever into neutral position, set parking brake, stop engine and remove key to prevent unintended starting.

Before lubricating, repairing, or inspecting, always disengage PTO, move shift lever into neutral position, set parking brake, stop engine and remove key to prevent unintended starting.



NOTE: Depending on the engine model found on your tractor, it may be necessary to remove the tractor's side panel in order to replace the oil filter (if so equipped).

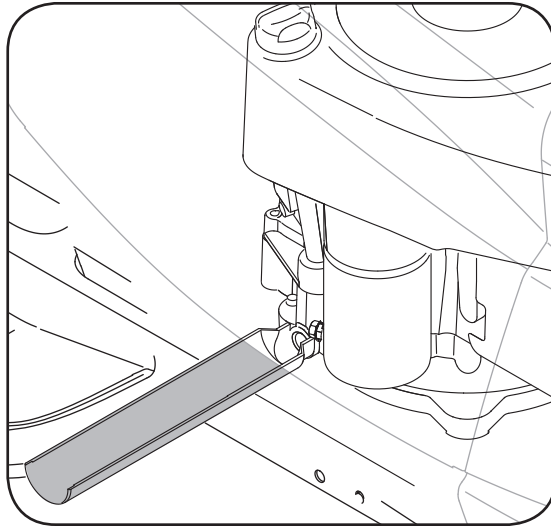

Figure 14



**WARNING:** Before performing any maintenance or repairs, disengage PTO, move shift lever into neutral position, set parking brake, stop engine and remove key to prevent unintended starting.

### Engine

Refer to the Engine Operator/Owner's Manual for engine maintenance instructions.

Check **engine oil level** before each use as instructed in the Engine Operator/Owner's Manual packed with your unit. **Follow the instructions carefully.**

### Changing Engine Oil

**NOTE:** Depending on the engine model found on your tractor, it may be necessary to remove the tractor's side panel in order to replace the oil filter (if so equipped).

For draining oil from the engine's crankcase of select model tractors, a plastic oil drain sleeve is packed with this Operator's Manual. To drain the oil, proceed as follows:

1. Unscrew the oil fill cap and remove the dipstick from the oil fill tube.
2. Snap the small end of oil drain sleeve onto the oil sump. See Figure 14.
3. Remove drain plug and drain oil into a suitable container with a capacity of no less than 64 oz.
4. Service the oil filter (if so equipped) as instructed in the separate Engine Operator/Owner's Manual packed with your unit.

Perform the above steps in the opposite order after oil has finished draining.

5. Refill the engine with new motor oil as instructed in the Engine Operator/Owner's Manual packed with your unit.

**IMPORTANT:** Refer to the Engine Operator/Owner's Manual packed with your unit for information regarding the quantity and proper weight of motor oil.

### Air Cleaner

Service the pre-cleaner, if so equipped, and cartridge/air cleaner element as instructed in the Engine Operator/Owner's Manual packed with your unit.

### Spark Plug

The spark plug should be cleaned and the gap reset once a season. Spark plug replacement is recommended at the start of each mowing season. Refer to the Engine Operator/Owner's Manual for correct plug type and gap specifications.

### Lubrication



**WARNING:** Before lubricating, repairing, or inspecting, always disengage PTO, move shift lever into neutral position, set parking brake, stop engine and remove key to prevent unintended starting.

### Engine

Lubricate the engine with motor oil as instructed in the Engine Owner's Manual packed with your unit.

### Pivot Points & Linkage

Lubricate all the pivot points on the drive system, parking brake and lift linkage at least once a season with light oil.

### Rear Wheels

The rear wheels should be removed from the axles once a season. Lubricate the axles and the rims well with an all-purpose grease before re-installing them.

### Front Axles

The front wheels should be removed from the axles once a season. Lubricate the axles and the rims well with an all-purpose grease before re-installing them.

### Cleaning the Engine And Deck

Any fuel or oil spilled on the machine should be wiped off promptly. Do NOT allow debris to accumulate around the cooling fins of the engine or on any other part of the machine.

**IMPORTANT:** The use of a pressure washer to clean your tractor is NOT recommended. It may cause damage to electrical components, spindles, pulleys, bearings or the engine.

## Deck Wash System™

A hex plug can be found on your tractor's deck surface. See Figure 15.

This plug can be replaced with a water port to be used as part of a separately-available deck wash system.

Use the Deck Wash System™ to rinse grass clippings from the deck's underside and prevent the buildup of corrosive chemicals.

**NOTE:** Refer to page 24 for information regarding this and other separately-available attachments & accessories for your tractor.

## Cutting Deck Removal

To remove the cutting deck, proceed as follows:

1. Place the PTO (Blade Engage) lever in the disengaged (OFF) position and engage the parking brake.
2. Lower the deck by moving the deck lift lever into the bottom notch on the right fender.
3. Remove the belt from around the tractor's engine pulley and idler pulley(s). Refer to **Changing the Deck Belt** on page 22 for detailed instructions.
4. Looking at the cutting deck from the left side of the tractor, locate the hair pin clip that secures the deck support rod on the rear left side of the deck. See Figure 16.
5. Remove the hair pin clip that secures the deck support rod, and carefully remove the deck support from the deck lift arm.
6. Repeat the above steps on the tractor's right side.
7. Move the deck lift lever into the top notch on the right fender to raise the deck lift arms up and out of the way.
8. Carefully remove the PTO cable from the rear of the cutting deck by removing the hair pin clip which secures it. Remove the spring from the deck idler bracket. See Figure 17.
9. Gently slide the cutting deck toward the front of the tractor allowing the hooks on the deck to release themselves from the deck stabilizer rod.
10. Gently slide the cutting deck (from the right side) out from underneath the tractor.

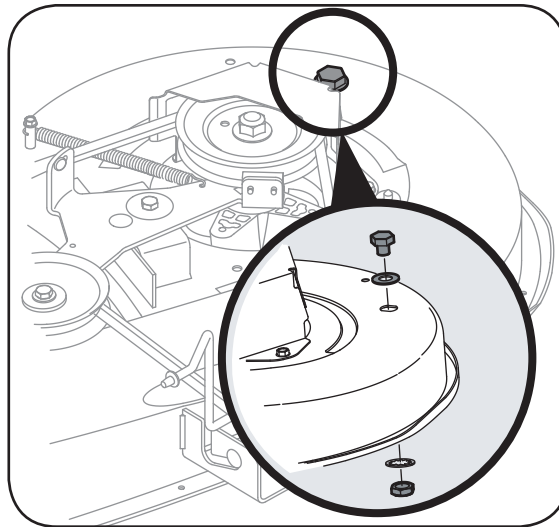

Figure 15

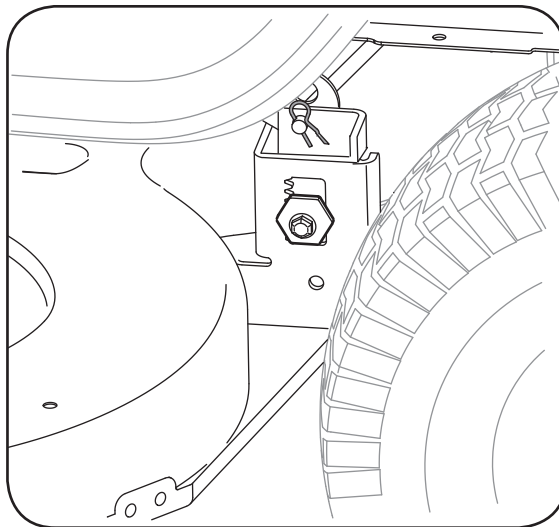

Figure 16

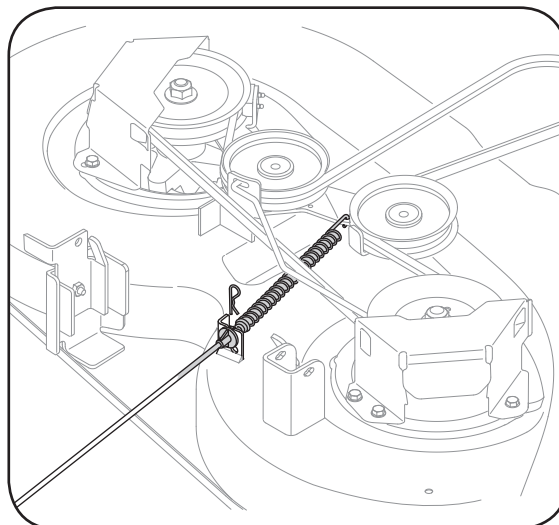

Figure 17

# 6

## Maintaining Your Lawn Tractor



### WARNING

Never exceed the maximum inflation pressure shown on the sidewall of the tire.

Batteries give off an explosive gas while charging. Charge battery in a well ventilated area and keep away from an open flame or pilot light as on a water heater, space heater, furnace, clothes dryer or other gas appliances.

Always use a fuse with the same amperage capacity for replacement.

### Tires



**WARNING:** Never exceed the maximum inflation pressure shown on the sidewall of tire.

The recommended operating tire pressure is:

- Approximately 10 psi for the rear tires
- Approximately 14 psi for the front tires

**IMPORTANT:** Refer to the tire sidewall for exact tire manufacturer's recommended or maximum psi. Do not overinflate. Uneven tire pressure could cause the cutting deck to mow unevenly.

### Battery

The battery is sealed and is maintenance-free. Acid levels cannot be checked.

- Always keep the battery cables and terminals clean and free of corrosive build-up.
- After cleaning the battery and terminals, apply a light coat of petroleum jelly or grease to both terminals.
- Always keep the rubber boot positioned over the positive terminal to prevent shorting.

**IMPORTANT:** If removing the battery for any reason, disconnect the NEGATIVE (Black) wire from its terminal first, followed by the POSITIVE (Red) wire. When re-installing the battery, always connect the POSITIVE (Red) wire its terminal first, followed by the NEGATIVE (Black) wire. Be certain that the wires are connected to the correct terminals; reversing them could change the polarity and result in damage to your engine's alternating system.

### Charging

If the tractor has not been put into use for an extended period of time, charge the battery with an automotive-type 12-volt charger for a minimum of **one hour at six amps**.



**WARNING:** Batteries give off an explosive gas while charging. Charge battery in a well ventilated area and keep away from an open flame or pilot light as on a water heater, space heater, furnace, clothes dryer or other gas appliances.

### Jump Starting



**WARNING:** When removing or installing the battery, follow these instructions to prevent the screwdriver from shorting against the frame.

**IMPORTANT:** Never jump your tractor's dead battery with the battery of a running vehicle.

1. Connect end of one jumper cable to the positive terminal of the good battery, then the other end to the positive terminal of the dead battery.
2. Connect the other jumper cable to the negative terminal of the good battery, then to the **frame of the unit with the dead battery**.



**WARNING:** Failure to use this procedure could cause sparking, and the gas in either battery could explode.

### Cleaning

Clean the battery by removing it from the tractor and washing with a baking soda and water solution. If necessary, scrape the battery terminals with a wire brush to remove deposits. Coat terminals and exposed wiring with grease or petroleum jelly to prevent corrosion.

### Battery Failures

Some common causes for battery failure are:

- incorrect initial activation
- undercharging
- overcharging
- corroded connections
- freezing

**These failures are NOT covered by your tractor's warranty.**

### Fuse

One 20 AMP fuse is installed in your tractor's wiring harness to protect the tractor's electrical system from damage caused by excessive amperage.

If the electrical system does not function, or your tractor's engine will not crank, first check to be certain that the fuse has not blown. It can be found under the hood mounted behind the dash panel on the right side.



**WARNING:** Always use a fuse with the same amperage capacity for replacement.

## Cutting Blades



**WARNING:** Be sure to shut the engine off, remove ignition key, disconnect the spark plug wire(s) and ground against the engine to prevent unintended starting before removing the cutting blade(s) for sharpening or replacement. Protect your hands by using heavy gloves or a rag to grasp the cutting blade.

**WARNING:** Periodically inspect the blade spindles for cracks or damage, especially if you strike a foreign object. Replace immediately if damaged.

The blades may be removed as follows.

1. Remove the deck from beneath the tractor, (refer to Cutting Deck Removal on page 19) then gently flip the deck over to expose its underside.
2. Place a block of wood between the center deck housing baffle and the cutting blade to act as a stabilizer. See Figure 18.
3. Use a 15/16" wrench to remove the hex flange nut that secures the blade to the spindle assembly. See Figure 18.
4. To properly sharpen the cutting blades, remove equal amounts of metal from both ends of the blades along the cutting edges, parallel to the trailing edge, at a 25° to 30° angle.

**IMPORTANT:** If the cutting edge of the blade has already been sharpened to within 1 5/8" from the edge, or if any metal separation is present, replace the blades with new ones. See Figure 19.

- It is important that each cutting blade edge be ground equally to maintain proper blade balance.
- A poorly balanced blade will cause excessive vibration and may cause damage to the tractor and result in personal injury. The blade can be tested by balancing it on a round shaft screwdriver. Grind metal from the heavy side until it balances evenly.
- When replacing the blade, be sure to install the blade with the side of the blade marked "Bottom" (or with a part number stamped in it) facing the ground when the mower is in the operating position.

**IMPORTANT:** Use a torque wrench to tighten the blade spindle hex flange nut to between 70 foot-pounds and 90 foot-pounds.

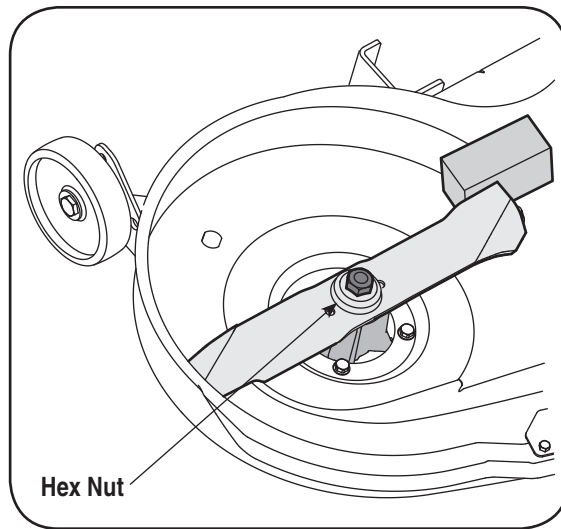

Figure 18

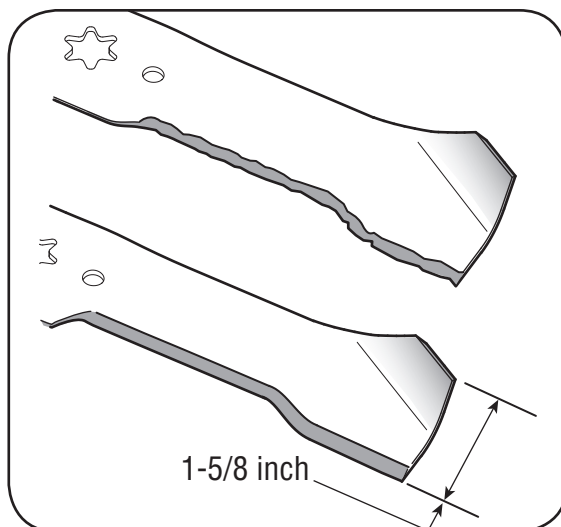

Figure 19

# 6

## Maintaining Your Lawn Tractor



### WARNING

Be sure to shut the engine off, remove ignition key, disconnect the spark plug wire(s) and ground against the engine to prevent unintended starting before removing the cutting blade(s) for sharpening or replacement. Protect your hands by using heavy gloves or a rag to grasp the cutting blade.

Periodically inspect the blade spindles for cracks or damage, especially if you strike a foreign object. Replace immediately if damaged.

# 6

## Maintaining Your Lawn Tractor



### WARNING

Be sure to shut the engine off, remove ignition key, disconnect the spark plug wire(s) and ground against the engine to prevent unintended starting before removing the belt(s).

Avoid the possibility of a pinching injury. Do not place your fingers on the idler spring or between the belt and a pulley while removing the belt.

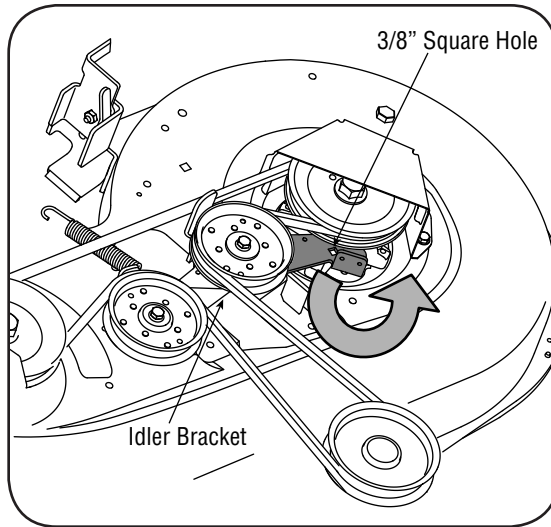

Figure 20

### Changing the Deck Belt



**WARNING:** Be sure to shut the engine off, remove ignition key, disconnect the spark plug wire(s) and ground against the engine to prevent unintended starting before removing the belt(s).

The belt on your tractor is subject to wear and should be replaced if any signs of wear are present.

**IMPORTANT:** The V-belt found on your tractor are specially designed to engage and disengage safely. A substitute (non-OEM) V-belt can be dangerous by not disengaging completely. For a proper working machine, use a factory approved belt.

To change or replace the deck belt proceed as follows:

1. Lower the deck by moving the deck lift lever into the bottom notch on the right fender.
2. Remove the belt guards by removing the self-tapping screws that fasten them to the deck.
3. Remove the belt keeper rod from around the engine pulley.
4. Insert a 3/8"-drive ratchet wrench (set to loosen) into the square hole found in the idler bracket on the left side of the deck's surface. See Figure 20.
5. Grasp the ratchet's handle and pivot it toward the front of the tractor to relieve tension on the belt.
6. With belt tension relieved, **carefully remove the belt from around the left-hand spindle pulley.**

**IMPORTANT:** Carefully allow the ratchet to pivot rearward before removing it from the square hole.



**WARNING:** Avoid the possibility of a pinching injury. Do not place your fingers on the idler spring or between the belt and a pulley while removing the belt.

7. Remove the deck belt from around all pulleys, including the deck idler pulley.
8. Route the new belt as shown in and Figure 21.
9. Remount the belt guards removed earlier.

### Changing the Transmission Drive Belts

**NOTE:** Several components must be removed and special tools (i.e. air/impact wrench) in order to change the tractor's drive belts. See an authorized Troybilt Service Dealer to have your drive belts replaced. To find a dealer near you, phone our dealer locator number as instructed on page 2 or log onto [www.troybilt.com](http://www.troybilt.com).

# 6

## Maintaining Your Lawn Tractor

42-Inch Deck

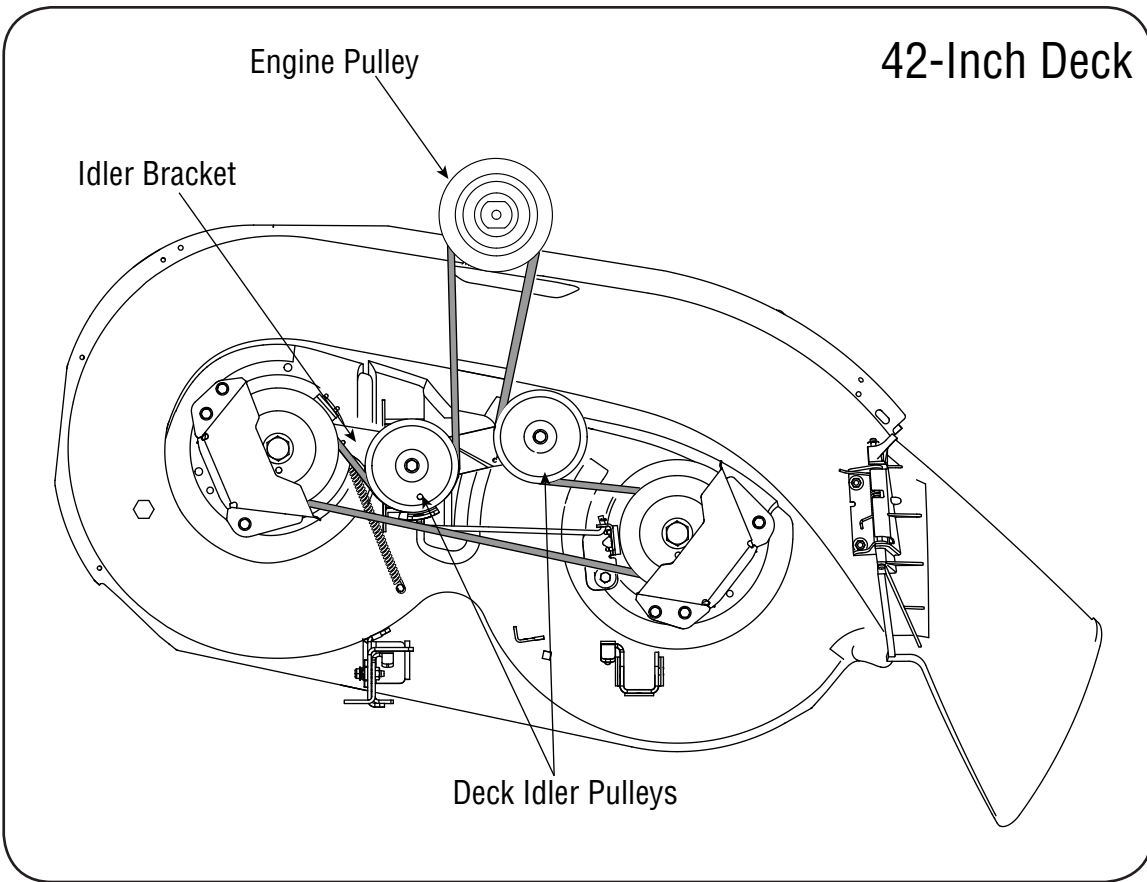

Figure 21

# 7

## Off-Season Storage/ Attachments



### WARNING

Drain fuel only into an approved container outdoors, away from an open flame. Allow engine to cool. Extinguish cigarettes, cigars, pipes, and other sources of ignition prior to draining fuel.

Never store the machine or fuel container indoors where there is an open flame, spark or pilot light such as on water heater, furnace, clothes dryer or other gas appliance.

Clean and lubricate the tractor as instructed in **Section 6: MAINTAINING YOUR LAWN TRACTOR** on page 18 of this manual before storing for an extended period.



**WARNING:** Drain fuel only into an approved container outdoors, away from an open flame. Allow engine to cool. Extinguish cigarettes, cigars, pipes, and other sources of ignition prior to draining fuel.

Follow the instructions in the **Service, Storage & Specifications** section of the Engine Operator/Owner's Manual for proper engine care prior to storing your tractor.



**WARNING:** Never store the machine or fuel container indoors where there is an open flame, spark or pilot light such as on water heater, furnace, clothes dryer or other gas appliance.

## Attachments & Accessories

The following attachments and accessories are compatible for Model Series 700 Lawn Tractors. See the retailer from which you purchased your tractor, an authorized Troybilt Service Dealer or phone (866) 840-6483 for information regarding price and availability.

**NOTE:** Model Series 700 Lawn Tractors are NOT designed for use with any type of ground-engaging attachments (e.g. tiller or plow). Use of this type of equipment WILL void the tractor's warranty.

MODEL	DESCRIPTION
OEM-190-032	42-inch Two-stage Snow Thrower
OEM-190-116	38/42-inch Deck Mulch Kit
OEM-190-180	Twin Bagger Grass Collector (for 38/42-inch Decks)
OEM-190-183	Deck Wheel Kit
OEM-190-218	Rear Wheel Weight Kit
OEM-190-607*	Deluxe Tractor Sunshade
OEM-190-658	Tire Chains, 20 x 8 Tires
OEM-190-672	Grille Guard (mounts on front of tractor)
OEM-190-833	42-inch Front Dozer Blade
490-900-0025	Deck Wash Kit

\* Not compatible with tractors equipped with a Grass Collector



# 8

## Safety Labels



**WARNING**

This symbol points out important safety instructions which, if not followed, could endanger the personal safety and/or property of yourself and others. Read and follow all instructions in this manual before attempting to operate this machine. Failure to comply with these instructions may result in personal injury. When you see this symbol, **HEED ITS WARNING!**

**Your Responsibility**  
Restrict the use of this power machine to persons who read, understand and follow the warnings and instructions in this manual and on the machine.

**⚠ DANGER**  
**ROTATING BLADES CAUSE SERIOUS INJURY OR DEATH**

- DO NOT MOW WHEN CHILDREN OR OTHERS ARE AROUND
- NEVER CARRY CHILDREN EVEN WITH BLADE(S) OFF.
- LOOK DOWN AND BEHIND BEFORE AND WHILE BACKING.
- MOWING IN REVERSE IS NOT RECOMMENDED.

**OPERATING MODES**

**NORMAL MOWING**  
YOU MUST DISENGAGE BLADES/PTO, (POWER TAKE OFF) BEFORE TRAVELING IN REVERSE.

**REVERSE CAUTION MODE**

- TURN KEY TO REVERSE CAUTION MODE POSITION.
- DEPRESS REVERSE PUSH BUTTON, (RED INDICATOR LIGHT "ON") WHEN RED LIGHT IS "ON" MACHINE CAN BE OPERATED IN REVERSE WITH MOWER BLADES ENGAGED.

**IMPORTANT! MOWING IN REVERSE IS NOT RECOMMENDED.**

- AFTER RESUMING FORWARD OPERATION, RETURN KEY TO "NORMAL MOWING" POSITION.

**NOTE:** IN BOTH MODES, WHEN OPERATOR LEAVES SEAT, ENGINE WILL STOP UNLESS PARKING BRAKE IS SET AND BLADES ARE DISENGAGED.

**⚠ WARNING**  
**TO AVOID SERIOUS INJURY OR DEATH**

- GO UP AND DOWN SLOPES, NOT ACROSS.
- AVOID SUDDEN TURNS.
- DO NOT OPERATE THE UNIT WHERE IT COULD SLIP OR TIP.
- IF MACHINE STOPS GOING UPHILL, STOP BLADE(S) AND BACK DOWNHILL SLOWLY.
- KEEP SAFETY DEVICES (GUARDS, SHIELDS, AND SWITCHES, ETC.) IN PLACE AND WORKING.
- REMOVE OBJECTS THAT COULD BE THROWN BY THE BLADE(S).
- KNOW LOCATION AND FUNCTION OF ALL CONTROLS.
- BE SURE BLADE(S) AND ENGINE ARE STOPPED BEFORE PLACING HANDS OR FEET NEAR BLADE(S).
- BEFORE LEAVING OPERATOR'S POSITION, DISENGAGE BLADE(S), ENGAGE PARKING BRAKE, SHUT OFF AND REMOVE KEY.

**READ OPERATOR'S MANUAL**

**⚠ BRAKE / CLUTCH PEDAL**  
**Brake / Clutch Pedal On Drivers Left Side Of Ride**

IF UNIT STALLS WITH SPEED CONTROL IN HIGH SPEED, OR IF UNIT WILL NOT OPERATE WITH SPEED CONTROL LEVER IN A LOW SPEED POSITION, PROCEED AS FOLLOWS:

- PLACE SHIFT LEVER IN NEUTRAL.
- RESTORY ENGINE.
- PLACE SPEED CONTROL LEVER IN HIGH SPEED POSITION.
- RELEASE CLUTCH-BRAKE PEDAL FULLY.
- DEPRESS CLUTCH-BRAKE PEDAL.
- PLACE SPEED CONTROL LEVER IN DESIRED POSITION.
- PLACE SHIFT LEVER IN EITHER FORWARD OR REVERSE AND FOLLOW NORMAL OPERATING PROCEDURES.

**Attachment Accessories Description / With Model Numbers**

<ul style="list-style-type: none"> <li>⚠ OEM-190-100</li> <li>3842R Blade Kit</li> <li>OEM-190-116</li> <li>3842Z Mulcher Kit</li> <li>818-190-010</li> <li>3842 Front Drive Shaft</li> </ul>	<ul style="list-style-type: none"> <li>OEM-190-022</li> <li>42 Snowblower Attachment</li> <li>818-190-010</li> <li>OEM-190-018</li> <li>818-190-018</li> <li>818-190-018</li> <li>818-190-018</li> </ul>	<ul style="list-style-type: none"> <li>818-190-010</li> <li>818-190-010</li> <li>818-190-010</li> <li>818-190-010</li> <li>818-190-010</li> <li>818-190-010</li> <li>818-190-010</li> <li>818-190-010</li> </ul>
---	--	--

**⚠ DANGER**  
**AVOID SERIOUS INJURY OR DEATH**

- KEEP HANDS AND FEET AWAY FROM ROTATING PARTS
- REMOVE OBJECTS THAT CAN BE THROWN BY THE BLADE IN ANY DIRECTION. WEAR SAFETY GLASSES.
- DO NOT MOW WHEN CHILDREN OR OTHERS ARE AROUND. NEVER CARRY CHILDREN EVEN WITH BLADES OFF.
- USE EXTRA CAUTION ON SLOPES. DO NOT MOW SLOPES GREATER THAN 15°. MOW UP AND DOWN, NOT ACROSS. AVOID SUDDEN TURNS. USE LOW SPEED.

**READ OPERATOR'S MANUAL. KEEP SAFETY DEVICES IN PLACE AND WORKING.**

S30018 MAX 15

**TO REDUCE THE RISK OF INJURY, DO NOT OPERATE UNLESS DISCHARGE COVER OR GRASS CATCHER IS IN ITS PROPER PLACE. IF DAMAGED, REPLACE IMMEDIATELY.**

**⚠ DANGER**  
**KEEP HANDS and FEET AWAY**

**⚠ DANGER**  
**KEEP HANDS AND FEET AWAY. DO NOT OPERATE MOWER UNLESS CHUTE DEFLECTOR OR ENTIRE GRASS CATCHER IS IN ITS PROPER PLACE.**

**ASSEMBLE CHUTE DEFLECTOR TO THIS UNIT BEFORE OPERATING.**

S30503

# 9

## Trouble Shooting



*For repairs beyond the minor adjustments listed here, contact an authorized service dealer.*

Problem	Cause	Remedy
Engine fails to start	<ol style="list-style-type: none"> <li>1. PTO engaged.</li> <li>2. Spark plug wire(s) disconnected.</li> <li>3. Fuel tank empty or stale fuel.</li> <li>4. Choke not activated.</li> <li>5. Faulty spark plug.</li> <li>6. Blocked fuel line.</li> <li>7. Engine flooded.</li> <li>8. Parking brake not engaged.</li> <li>9. Throttle control lever not in correct starting position.</li> </ol>	<ol style="list-style-type: none"> <li>1. Place PTO knob (or lever) in disengaged (OFF) position.</li> <li>2. Connect wire(s) to spark plug(s).</li> <li>3. Fill tank with clean, fresh gasoline.</li> <li>4. Pull out the CHOKE control (if so equipped) or place the throttle control in CHOKE position.</li> <li>5. Clean, adjust gap, or replace.</li> <li>6. Clean fuel line or replace fuel filter, if so equipped.</li> <li>7. Crank engine with throttle in FAST position.</li> <li>8. Engage parking brake.</li> <li>9. Place throttle lever to FAST position.</li> </ol>
Engine runs erratic	<ol style="list-style-type: none"> <li>1. Unit running with CHOKE applied.</li> <li>2. Spark plug wire(s) loose.</li> <li>3. Blocked fuel line or stale fuel.</li> <li>4. Vent in gas cap plugged.</li> <li>5. Water or dirt in fuel system.</li> <li>6. Dirty air cleaner.</li> </ol>	<ol style="list-style-type: none"> <li>1. Push CHOKE control (if so equipped) in, or move the throttle control out of the CHOKE position.</li> <li>2. Connect and tighten spark plug wire(s).</li> <li>3. Clean fuel line; fill tank with clean, fresh (less than 30 days old) gasoline. Replace fuel filter, if so equipped.</li> <li>4. Clear vent or replace if damaged.</li> <li>5. Drain fuel tank. Refill with fresh fuel.</li> <li>6. Replace air cleaner cartridge/element or clean pre-cleaner, if so equipped.</li> </ol>

<b>Problem</b>	<b>Cause</b>	<b>Remedy</b>
Engine overheats	<ol style="list-style-type: none"> <li>1. Engine oil level low.</li> <li>2. Air flow restricted.</li> </ol>	<ol style="list-style-type: none"> <li>1. Fill crankcase with proper oil.</li> <li>2. Clean grass clippings and debris from around the engine's cooling fins and blower housing.</li> </ol>
Engine hesitates at high RPM	<ol style="list-style-type: none"> <li>1. Spark plug(s) gap too close.</li> </ol>	<ol style="list-style-type: none"> <li>1. Remove spark plug(s) and reset the gap.</li> </ol>
Idles poorly	<ol style="list-style-type: none"> <li>1. Spark plug(s) fouled, faulty or gap too wide.</li> <li>2. Dirty air cleaner.</li> </ol>	<ol style="list-style-type: none"> <li>1. Replace spark plug(s). Set plug(s) gap.</li> <li>2. Replace air cleaner cartridge/element or clean pre-cleaner, if so equipped.</li> </ol>
Excessive Vibration	<ol style="list-style-type: none"> <li>1. Cutting blade loose or unbalanced.</li> <li>2. Damaged or bent cutting blade.</li> </ol>	<ol style="list-style-type: none"> <li>1. Tighten blade and spindle. Balance blade.</li> <li>2. Replace blade.</li> </ol>
Mower will not mulch grass (If Equipped)	<ol style="list-style-type: none"> <li>1. Engine speed too low.</li> <li>2. Wet grass.</li> <li>3. Excessively high grass.</li> <li>4. Dull blade.</li> </ol>	<ol style="list-style-type: none"> <li>1. Place throttle control in FAST (rabbit) position.</li> <li>2. Do not mow when grass is wet; wait until later to cut.</li> <li>3. Mow once at a high cutting height, then mow again at desired height or make a narrower cutting path.</li> <li>4. Sharpen or replace blade.</li> </ol>
Uneven cut	<ol style="list-style-type: none"> <li>1. Deck not balanced properly.</li> <li>2. Dull blade.</li> <li>3. Uneven tire pressure.</li> </ol>	<ol style="list-style-type: none"> <li>1. Perform side-to-side deck adjustment.</li> <li>2. Sharpen or replace blade.</li> <li>3. Check tire pressure in all four tires.</li> </ol>

# 9

## Trouble Shooting



***For repairs beyond the minor adjustments listed here, contact an authorized service dealer.***

Model 77T

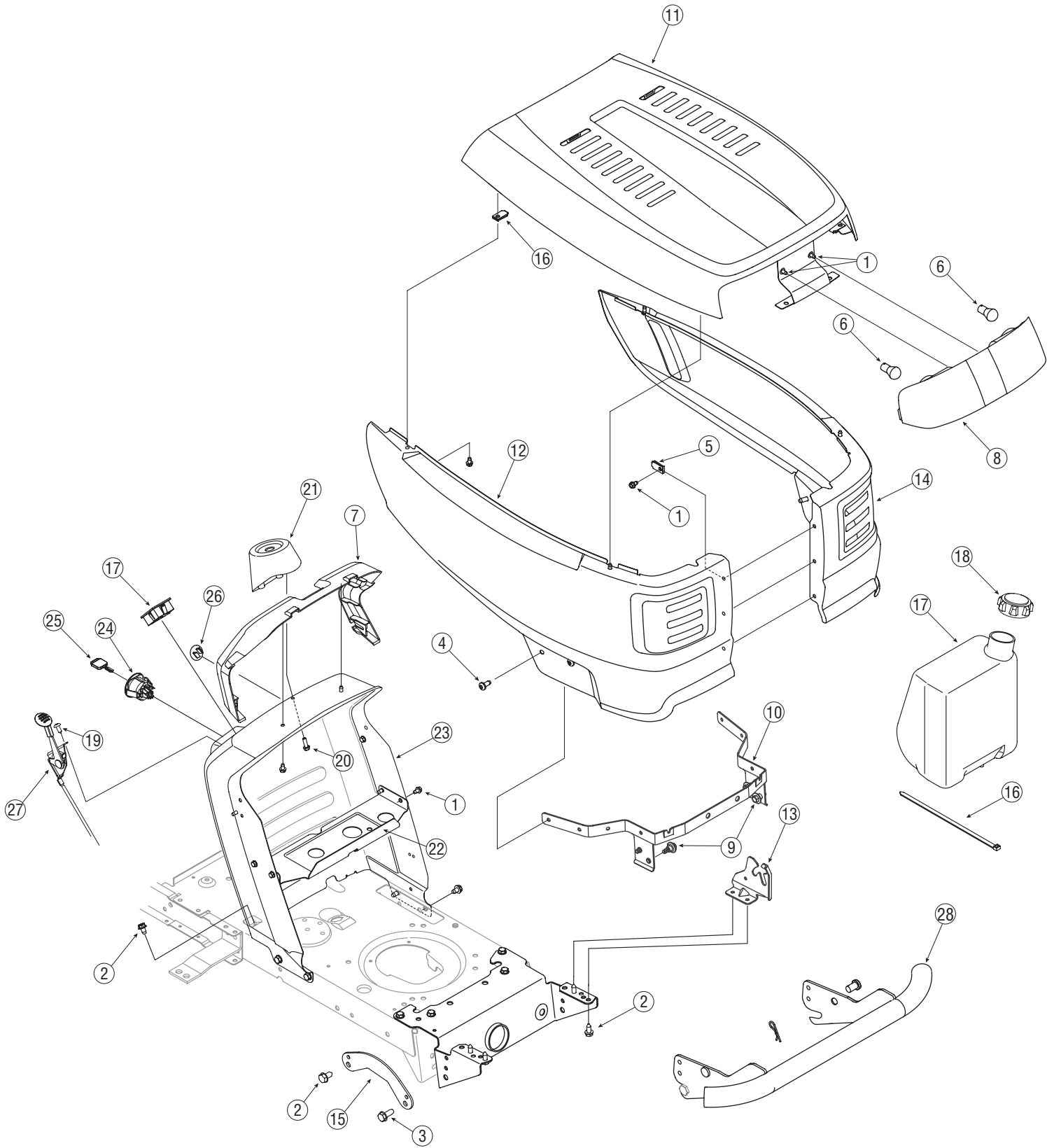

# 10

## Illustrated Parts List



*For parts and/or  
accessories  
please call  
1-866-840-6483, or  
1-330-558-7220.  
www.troybilt.com*

Ref. No.	Part No.	Description
1	710-0599	Screw, 1/4-20, 0.500
2	710-0604A	Screw, 5/16-18, 0.625
3	710-1260A	Screw, 5/16-18, 0.750
4	710-1611B	Screw, 5/16-18, 0.750
5	712-0185	Nut, 1/4-20, Speed U-type
6	725-0963	Headlamp, 12V
7	731-05078A	Collar, Dash, 3-Style
8	731-15357	Troy-Bilt Lens
9	738-04091	Screw, Shldr, .43 x .29, 5/16-18
10	783-04606A	Pivot Bracket
11	783-04827	Troy-Bilt Hood
12	783-04828	Troy-Bilt Side Panel, RH
13	783-04841	Hood Pivot Bracket, LH
	783-04840	Hood Pivot Bracket, RH
14	783-04967	Troy-Bilt Side Panel, LH

Ref. No.	Part No.	Description
15	783-05027	Front Pivot Support Bracket
16	726-0230	Cable Tie, 34.75
17	751-0555B	Fuel Tank, 1.5 gal.
18	751-0603	Fuel Tank Cap
19	710-04483	Screw, 1/4-14, .500
20	710-0895	Screw, 1/4-15, .750
21	731-04945	Support, Steering
22	783-04584	Gas Tank Support Bracket
23	783-04873	Dash Assembly
24	725-1741	Module, Ignition Switch
25	725-1744	Key
26	731-05265	Choke Plug
27	746-04258	Throttle/Choke Control, 25.0
—	725-04361	Wire Harness (No RMC)
28	190-672*	Bumper Kit

\*Models So Equipped

Models 77T

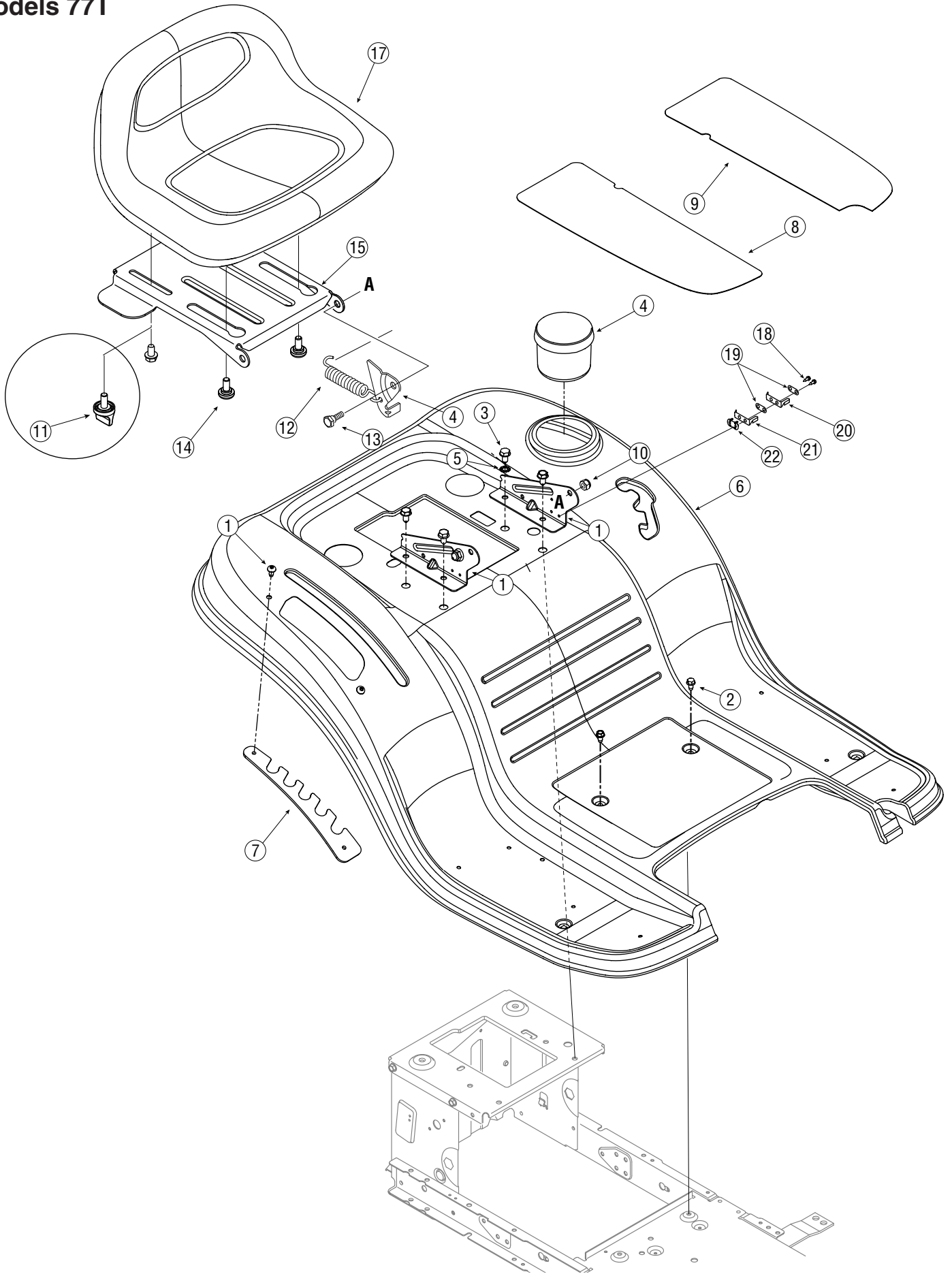

# 10

## Illustrated Parts List



*For parts and/or  
accessories  
please call  
1-866-840-6483, or  
1-330-558-7220.*

[www.troybilt.com](http://www.troybilt.com)

Ref. No.	Part No.	Description
1	710-04483	Screw, 1/4-20 x .500
2	710-0599	Screw, 1/4-20, 0.500
3	710-0604A	Screw, 5/16-18, 0.625
4	731-04591A	Cup Holder
5	736-0607	Lock Washer, 5/16
6	783-04587A	Fender
7	783-1489B	Mounting Bracket, Seat
8	723-04025	Foot Pad, Abrasive, RH
9	723-04026	Foot Pad, Abrasive, LH
10	712-04063	Nut, Flange Lock, 5/16-18, GrF
11	720-04061	Knob, 3/8-16, .875
12	732-1184	Spring, Exten., .84 Dia x 4.6 Lg.
13	738-0296	Scr., Shlder, .437 x .268, 5/16-18
14	738-04012A	Screw, Shlder, .625 x .175, 3/8-16
15	783-04081A	Pivot Bracket, Seat
16	783-0209D	Lift Bracket, Seat
17	757-04021A	Seat, Low, Black
18	710-0227	Screw, #8-18 x .50
19	726-0279	Plate, Insulator
20	725-1303	Spring Switch, Outer
21	725-1439	Spring Switch, Inner
22	726-0278	Plate, Insulator Boss

# Models 77T

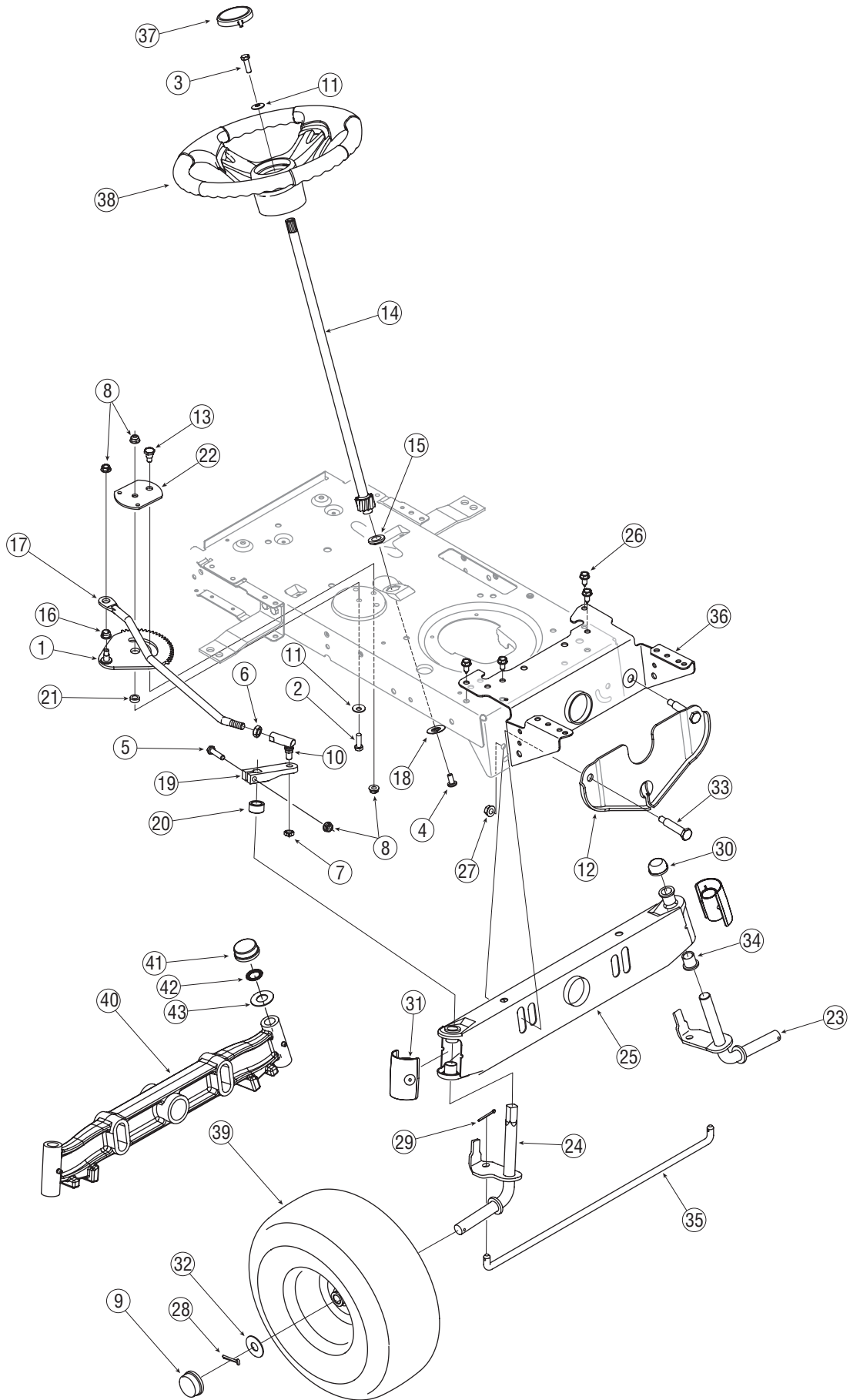



# 10

## Illustrated Parts List



**For parts and/or  
accessories  
please call  
1-866-840-6483, or  
1-330-558-7220.  
[www.troybilt.com](http://www.troybilt.com)**

Ref. No.	Part No.	Description
1	617-04024	Gear Assembly, Steering
2	710-0376	Screw, 5/16-18, 1.00, Gr5
3	710-0643	Screw, 5/16-18, 1.00, Gr5, Lock
4	710-1309	Screw, Mach, 5/16-18, 0.750
5	710-3180	Screw, 5/16-18, 1.75, Gr5
6	712-0240	Nut, Jam, 7/16-20, Gr2
7	712-0262	Nut, Jam Lock, 3/8-24, Gr2
8	712-04063	Nut, Flange Lock, 5/16-18, GrF
9	731-0484A	Hub Cap
10	723-0448A	Ball Joint, 7/16-20, Lock
11	736-0242	Washer, Bell, .340 x .872 x .060
12	783-04568	Front Hanger Bracket, Deck
13	738-04141	Scr., Shlder, .435 x .3485, 5/16-18
14	738-0919	Steering Shaft, 5/8 Spline x 21.86
15	741-04124	Bearing, Flange, Hex 5/8
16	741-0475	Plastic Bushing .380 ID
17	747-04298	Drag Link, Steering
18	748-0389	Cap, 1.25 x .16
19	748-04065	Steering, Block
20	748-04068	Spacer, .710 ID x .125 OD x .56
21	750-04418	Spacer, .322 ID x .625 OD x .21
22	783-04644	Stabilizer Plate, Gear Segment
23	638-04007	Axle Assembly, LH

Ref. No.	Part No.	Description
24	638-04008	Axle Assembly, RH
25	683-0128B	Pivot Bar
26	710-0726	Screw, 5/16-12, 0.750
27	712-04065	Nut, Flange Lock, 3/8-16, GrF
28	714-04039	Pin, Cotter, 5/32, 1.25
29	714-0470	Pin, Cotter, 1/8 x 1.25
30	726-0341	Push Cap, 3/4
31	731-04057A	End Cap, Pivot Bar (w/ Fitting)
32	736-0316	Washer, Flat, .78 x 1.59 x .060
33	738-04128	Scr., Shlder, .500 x 2.380, 3/8-16
34	741-0660A	Bearing, Flange, .760 x .941 x 1.0
35	747-04299A	Tie Rod
36	783-04601B	Bracket, Pivot
37	731-04681	Cap, Steering Wheel (tine logo)
38	631-04028	Steering Wheel, Standard Grip
39	634-04086	Wheel Ass'y, Square Shoulder
	734-1731	Tire Only, 15 x 6 x 6, Square Shld.
	634-04081	Rim Assembly (Incl. bearings & stem)
40	719-04105	Pivot Bar, Cast Iron
41	731-04693	Push Cap
42	726-04035	Push Nut, 3/4"
43	736-0316	Flat Washer, .78 x 1.59 x .060

# Models 77T

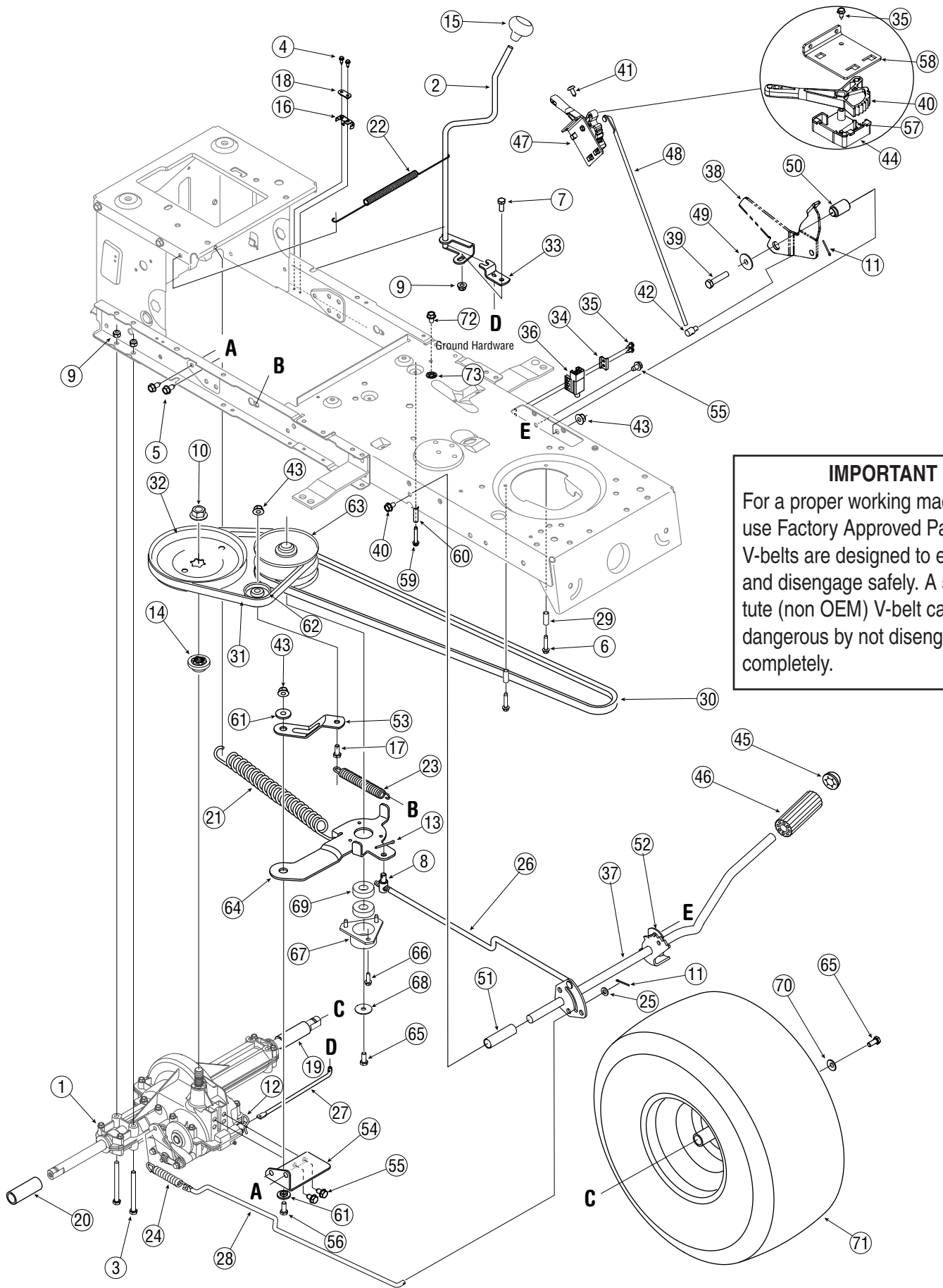

**IMPORTANT**  
 For a proper working machine, use Factory Approved Parts. V-belts are designed to engage and disengage safely. A substitute (non OEM) V-belt can be dangerous by not disengaging completely.

# 10

## Illustrated Parts List



*For parts and/or  
accessories  
please call  
1-866-840-6483, or  
1-330-558-7220.  
www.troybilt.com*

Ref. No.	Part No.	Description
1	618-04034	Transmission Assembly
2	647-04035	Lever Assembly, Shift
3	710-0176	Screw, 5/16-18, 2.75, Gr5
4	710-0227	Screw, #8-18, 0.500
5	710-0726	Screw, 5/16-12, 0.750
6	710-0809	Screw, 1/4-20, 1.250
7	710-3008	Screw, 5/16-18, .75, Gr5
8	711-04075A	Ferrule, 3/8-24 x .375 Dia.
9	712-04063	Nut, Flange Lock, 5/16-18, GrF
10	712-0700	Nut, Flange, 9/16-18, Gr2
11	714-0111	Pin, Cotter, 3/32, 1.0
12	714-0209	Cotter Pin, Internal .125 Dia
13	714-0470	Pin, Cotter, 1/8 x 1.25
14	718-0758A	Hub, Pulley, 5/8 Spline
15	720-04028	Knob, Shift
16	725-1644	Spring Switch, Short
17	710-0520	Screw, 3/8-16 x 1.50
18	726-0320	Plate, Insulator Nut
19	731-04602	Sleeve, .758 x .821 x 3.3125
20	731-04604	Sleeve, .758 x .821 x 2.4375
21	732-04076A	Spring, Extension, 1.15 OD x 7.90
22	732-04237	Spring, Extension, .50 OD x 12.0
23	732-04306	Spring, Extension, .80 OD x 3.28
24	732-0716C	Spring, Extension, .59 OD x 4.00
25	736-0264	Washer, Flat, .330 x .630 x .0635
26	747-04265	Control Rod, Variable Speed
27	747-04277	Rod, Shift
28	747-04287	Rod, Brake
29	750-0566A	Spacer, .260 x .372 x 1.030
30	754-04001A	Belt
31	754-0241A	Belt
32	756-04002	Pulley, V-Type, 7.25 Dia
33	783-04595	Shift Bracket, Adjustable
34	17962	Plate, Switch
35	710-0224	Screw, #10-16, 0.500
36	725-04039	Switch, Interlock
37	647-04034C	Pedal Assembly, Drive
38	783-04903	Latch Bracket (No RMC)

Ref. No.	Part No.	Description
39	710-1008	Screw, 3/8-16, 1.875, Gr5
40	731-05362	7 Speed Shift Lever
41	710-04483	Screw, 1/4-20, 0.500
42	711-0736	Adjustment Ferrule 1/4-20
43	712-04065	Nut, Flange Lock, 3/8-16, GrF
44	731-05361	Control Cover
45	726-0214	Push Cap, 5/8
46	735-0239	Pad, Foot, 4.0
47	683-04216	Shift Cont. Assembly, 7-Speed
48	747-04430	Control Rod, Speed Selector
49	736-0247	Washer, Flat, .406 x 1.25 x .157
50	750-04465	Spacer, Flge, .390 x .671 x 1.095
51	750-0802	Spacer, .640 ID x .76 OD x 2.63
52	783-04536	Support Bracket, Pedal
53	683-04207	Bracket, Idler
54	683-04176A	Torque Bracket, Transmission
55	710-0604A	Screw, 5/16-18, 0.625
56	710-0520	Screw, 3/8-16, 1.50, Gr5
57	732-0627	Shift Lever Spring
58	783-04830	Control Bracket
59	710-1325	Screw, 1/4-20 x 1.625
60	750-04456	Spacer, .260 x .372 x 1.420
61	738-0347	Spacer, Shoulder, .625 ID x .169
62	756-04213	Pulley, Flat Idler
63	656-04015	Pulley Ass'y, Variable Speed
64	683-04206	Bracket Ass'y, Variable Speed
65	710-0627	Screw, 5/16-24, .750, Gr5
66	710-1652	Screw, 1/4-20, 0.625
67	718-04012	Cup, Bearing
68	736-0362	Washer, Flat, .330 x 1.25 x .06
69	741-0600	Bearing, Ball, 17 x 40 x 12
70	736-0242	Bell Washer, .34 x .872 x .060
71	634-0104	Wheel Ass'y, Square Shoulder
	734-1730	Tire Only, 20 x 8 x 8, Square Shld
	734-0603A	Rim Assembly (Inc. bearings & stem)
72	710-0599	Screw, 1/4-20 x .500
73	736-0222	Lock Washer, 1/4

# Models 760-779

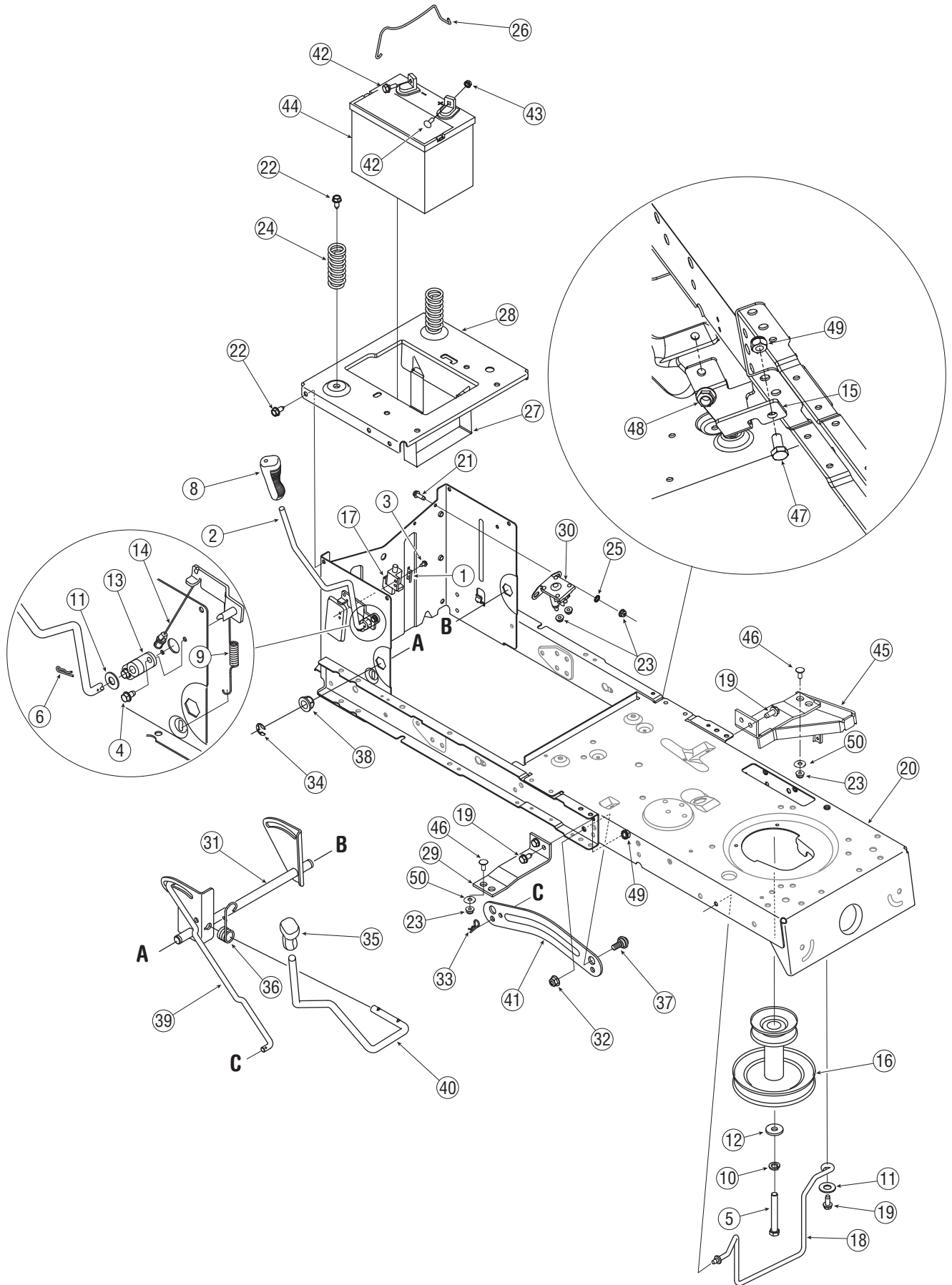

Ref. No.	Part No.	Description
1	17962	Plate, Switch
2	647-04040	Handle Asswmbly, PTO
3	710-0224	Screw, #10-16, 0.500
4	710-0599	Screw, 1/4-20, 0.500
5	710-3157	Screw, 7/16-20, 3.25, Gr5
6	714-0104	Pin, Cotter, .072 Dia. x 1.13
7	714-0145	Pin, Click, .092 x 1.64
8	720-04049	Grip, Handle, 3/8
9	732-04276	Spring, Extension
10	736-0171	Washer, Lock, 7/16
11	736-0300	Washer, Flat, .406 x .875 x .059
12	736-0322	Washer, Flat, .450 x 1.250 x .164
13	741-04119	Bearing, PTO
14	746-04173A	Cable, Deck Engagement
15	783-04753	Frame Support Bracket
16	756-04196	Engine Pulley, 3.39 x 6.12 Dia.
17	725-04039	Switch, Interlock
18	747-04307	Rod, Belt Keeper (42-inch Deck)
19	710-1260A	Screw, 5/16-18, .750
20	683-04163A	Frame Assembly
21	710-0642	Screw, 1/4-20, 0.750
22	710-0604A	Screw, 5/16-18, 0.625
23	712-04064	Nut, Flange Lock, 1/4-20, GrF
24	732-04035	Spring, Compr. , 1.28 OD x 3.125
25	736-0222	Washer, Lock, 1/4
26	747-04385	Hold Down Rod, Battery
27	783-04869	Bracket, Battery

Ref. No.	Part No.	Description
28	783-04548A	Seat Bracket, Frame
29	783-04637	Bracket, Runing Board
30	725-1426A	Solenoid
31	683-04155	Shaft Assembly, Lift
32	712-04065	Nut, Flange Lock, 3/8-16, GrF
33	714-04043	Pin, Cotter, .080 x 1.5625 Internal
34	716-0106A	Ring, E-Type, .625 Dia.
35	720-0311	Grip, Handle, 1/2
36	732-04225	Spring, Torsion
37	738-04130	Screw, Shldr. , .625 x .175, 3/8-16
38	741-0225	Bearing, Hex Flange
39	747-04393	Rod, Lift
40	747-04282	Deck Handle, Lift
41	783-04494	Lift Arm, Deck - RH
	783-04711	Lift Arm, Deck - LH
42	710-0703	Screw, Carriage, 1/4-20, .75, Gr5
43	712-0271	Nut, Sems, 1/4-20
44	725-1737A	Battery, 190 CCA
45	683-04195	Support Bracket Assembly
46	710-0134	Carriage Screw, 1/4-20 x .62
47	710-3025	Screw, 5/16-18 x .625
48	712-04063	Flange Lock Nut, 5/16-18
49	712-0429	Hex Lock Nut, 5/16-18
50	736-0173	Flat Washer, .28 x .74 x .063

# 10

## Illustrated Parts List



*For parts and/or  
accessories  
please call  
1-866-840-6483, or  
1-330-558-7220.  
www.troybilt.com*

Models 760-779

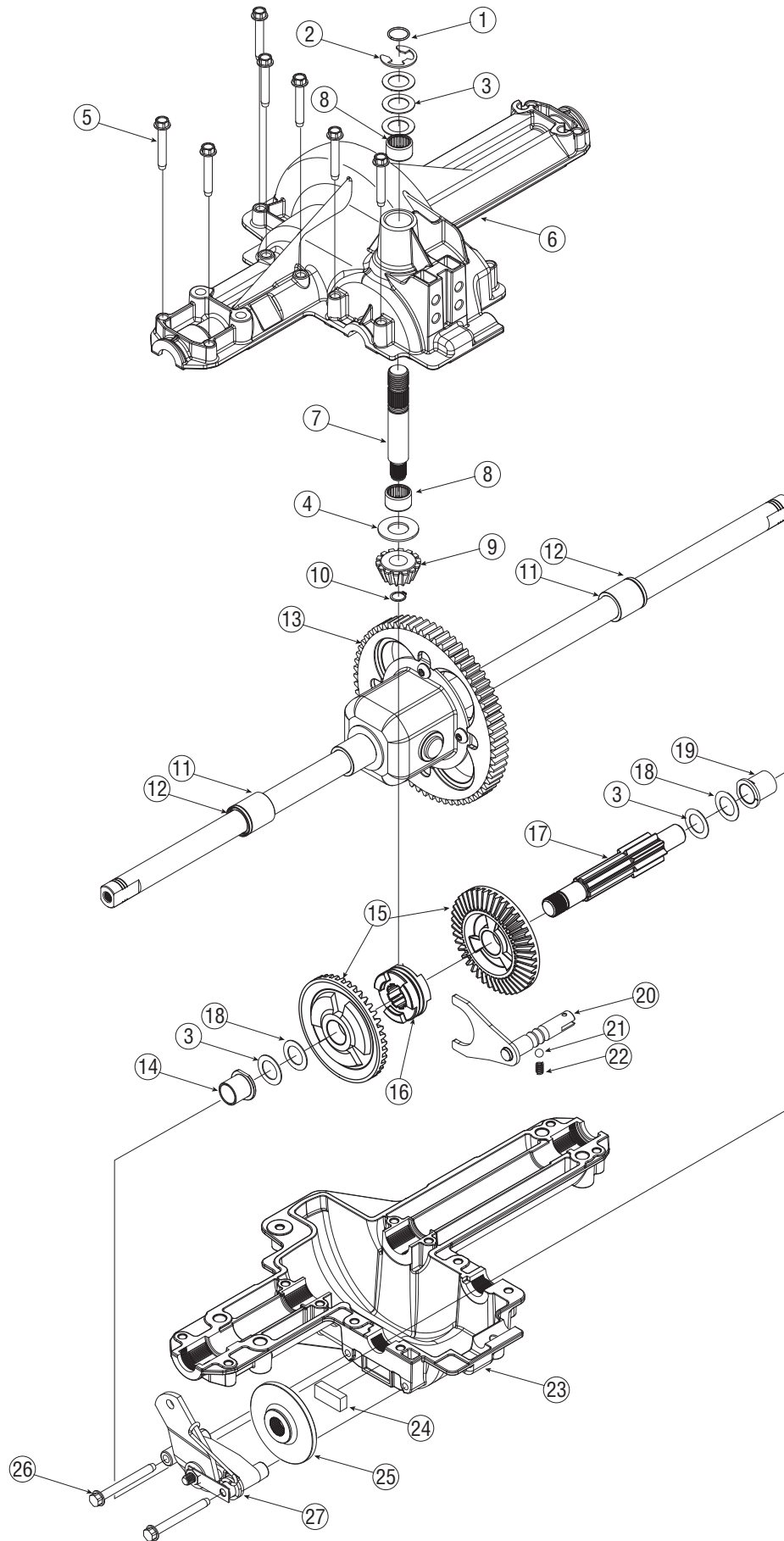

# 10

## Illustrated Parts List



*For parts and/or  
accessories  
please call  
1-866-840-6483, or  
1-330-558-7220.  
www.troybilt.com*

Ref. No.	Part No.	Description
1	732-0614	Ring, Wire
2	716-0231	Ring, E Type,.750
3	736-0336*	Flat Washer, 5/8 x 1.0 x.030
	736-0337*	Flat Washer, 5/8 x 1.0 x.040
	736-0349*	Flat Washer, 5/8 x 1.0 x.020
4	736-0335	Washer, Thrust.635 x 1.26 x.06
5	710-1325	Self-tapping Screw, 1/4-20 x 1.625
6	719-04017	Upper Housing
7	711-1109	Input Shaft
8	741-0335	Needle Bearing,.625 x.813 x.495
9	717-1464	14-tooth Bevel Pinion
10	716-0108	Retaining Ring,.437
11	741-0340	Sleeve Bearing,.75 x1.0 x 1.0
12	721-0338	Seal,.75 x 1.0 x.125
13	618-04041	Differential Assembly
14	741-0336	Flange Bearing, 5/8 x 3/4 x 3/4
15	717-04056	42-tooth Bevel Gear
16	718-04045	Clutch Collar
17	711-04134	Drive Shaft
18	736-0495*	Thrust Washer, 1.0 x.632 x.0
	736-0494*	Flat Washer,.632 x 1.00 x.035
19	741-0337	Flange Bearing, 5/8 x 3/4 x 15/16
20	611-0011	Detent Shaft Assembly
21	741-0862	Detent Ball
22	732-0863	Compression Spring
23	719-04018	Lower Housing
24	717-0678	Brake Puck
25	761-0202	Brake Disc
26	710-1206	Self-tapping Screw, 1/4-20 x 2.375
27	661-0001	Brake Assembly
—	737-0148	Grease (19 oz.)

\* Use applicable flat washer (ref. #'s 3 or 18) in this application allowing .0150/.0020 in. end-play

**NOTE:** If rebuilding the upper housing, include two ounces (2 oz.) of Unirex® N3 grease (Part No. 737-0289) in the input shaft cavity.

# Models 77T (42" Deck)

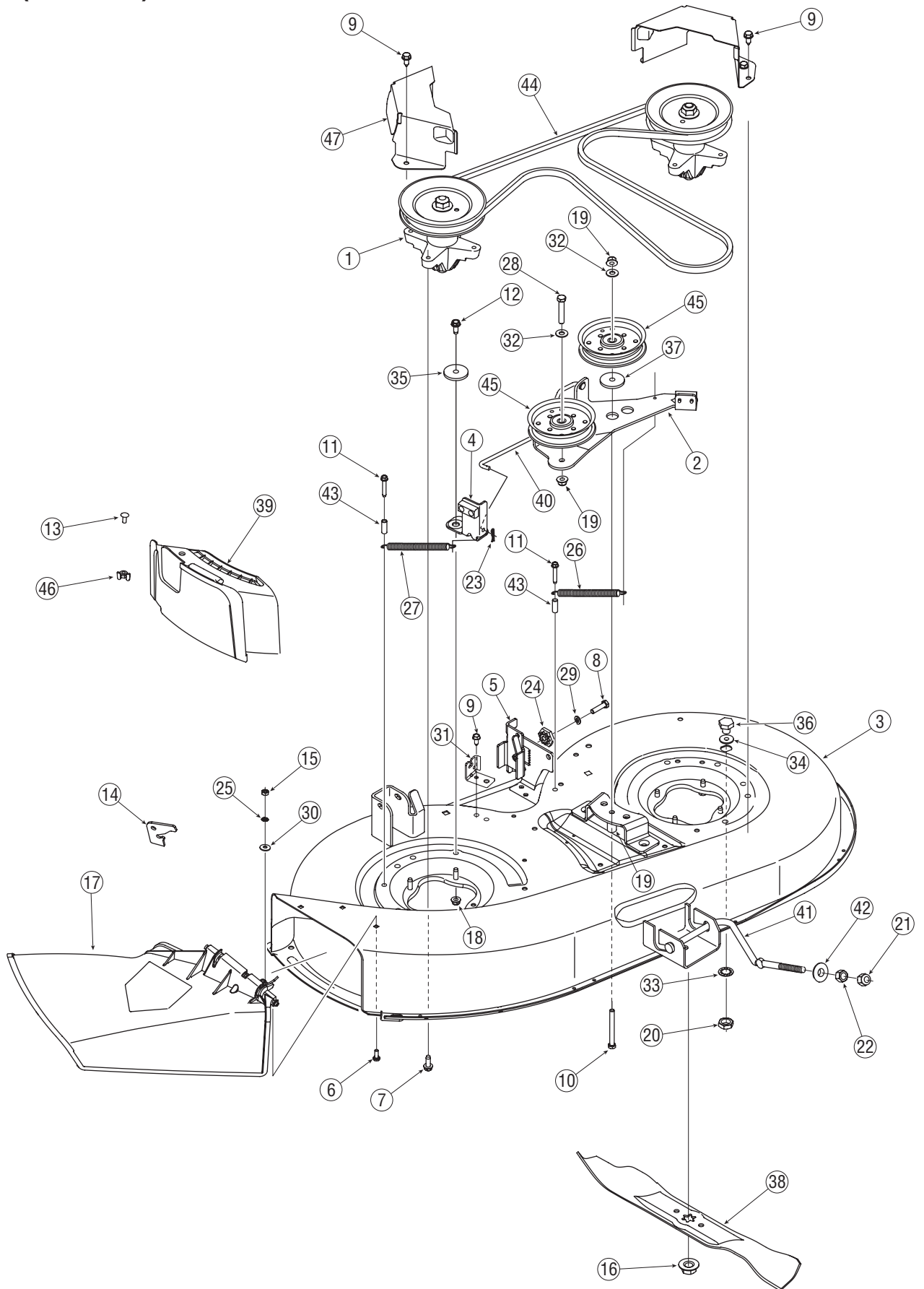



# 10

## Illustrated Parts List



*For parts and/or  
accessories  
please call  
1-866-840-6483, or  
1-330-558-7220.  
www.troybilt.com*

Ref. No.	Part No.	Description
1	618-0624	Spindle Assembly, Pul, 6.23" Dia
2	683-04138A	Brake Assembly, Deck
3	683-04165A	Deck Shell, 42" (w/o Wheel Brkt)
4	683-04167	Brake Assembly, Deck
5	683-04228	Brkt. Ass'y, Deck, Hanger LH
6	710-3015	Screw, 1/4-20, .75, Gr5
7	710-1260A	Screw, 5/16-18, 0.750
8	710-0528	Screw, 5/16-18, 1.250
9	710-0604A	Screw, 5/16-18, 0.625
10	710-3085	Screw, 3/8-16, 3.50, Gr5
11	710-0778	Screw, 1/4-20, 1.500
12	710-3008	Screw, 5/16-18, .75, Gr5
13	710-0134†	Carriage Screw, , 1/4-20 x .62
14	783-1025	Chute Stop
15	712-3006	Nut, Hex, 1/4-20, Gr5
16	712-0417A	Nut, Flange, 5/8-18
17	731-1032B	Chute Assembly, Discharge
18	712-04063	Nut, Flange Lock, 5/16-18, GrF
19	750-04446	Spacr, 3/8 ID x .68 OD x 1.46 Lg.
20	712-0641	Nut, Hex, M16-1.5
21	712-3083	Nut, Hex Lock, 1/2-13, Gr8
22	712-0206	Nut, Hex, 1/2-13, Gr5
23	714-0104	Pin, Cot, .072 Dia. x 1.13 Lg
24	717-04074	Gear, Deck Adjustment

Ref. No.	Part No.	Description
25	726-0233	Nut, Push, .25 ID x .50 OD
26	732-04280A	Spring, Exten. , .75 Dia. x 6.375
27	732-04287	Spring, Exten. , .50 Dia. x 6.375
28	710-0347	Screw, 3/8-16 x 1.75
29	736-0119	Washer, Lock, 5/16
30	736-0270	Washer, Bell, .265 x .75 x .062
31	783-04740	Deck Engagement Cable Bracket
32	736-0267	Washer, Flat, .385 x .87 x .06
33	736-0225	Washer, Lock, 5/8, Internal Tooth
34	736-0187	Washer, Flat, .64 x 1.24 x .06
35	738-04166	Spacer, Shoulder, .5000 x .1475
36	738-04146	Plug, Screw, M16 x 1.5
37	738-04162A	Spacer, Shoulder, .8840 x .190
38	742-0616A	Blade, 21.23", Star 3-in-1
39	731-2363†	Mulch Plug
40	747-04379A	Control Rod, Brake
41	747-04269A	Deck Rod, Front Adjustable
42	748-04069	Pivot Cup, Deck Lift
43	750-0566A	Spacer, .260 x .372 x 1.030
44	754-04060B	Belt, V-Type
45	756-04129	Idler Pulley, 4.25" Dia.
46	712-3087†	Wing Nut, 1/4-20
47	783-04327A	Cover, Belt, 6.00 Dia.

† Optional

### IMPORTANT

For a proper working machine,  
use Factory Approved Parts.  
**V-belts** are designed to  
engage and disengage safely.  
A substitute (non OEM) V-belt  
can be dangerous by not  
disengaging completely.

Models 77T

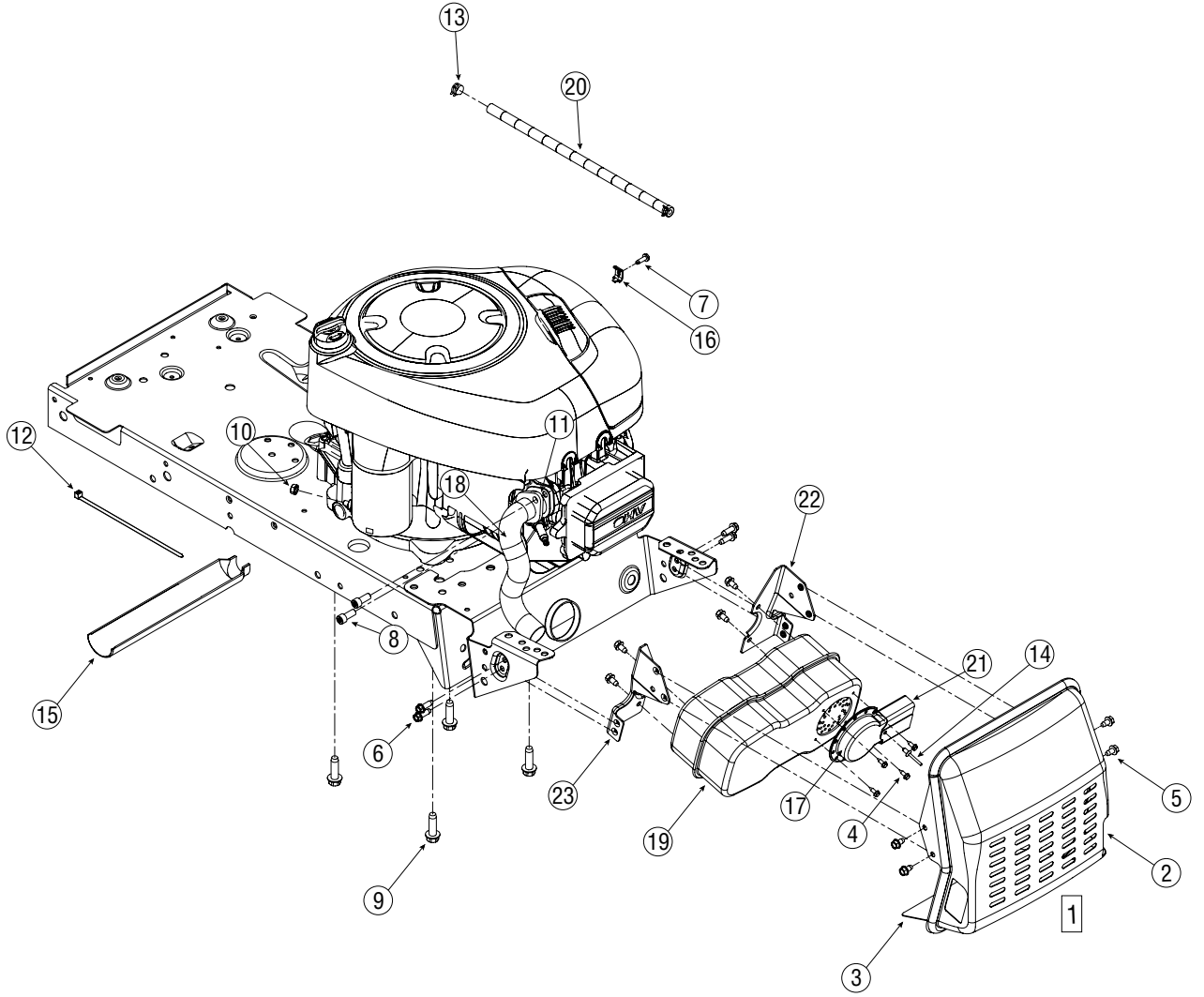

# 10

## Illustrated Parts List



*For parts and/or  
accessories  
please call  
1-866-840-6483, or  
1-330-558-7220.  
[www.troybilt.com](http://www.troybilt.com)*

Ref. No.	Part No.	Description
1	683-04256	Muffler Shield Assembly
2	783-04576	Muffler Shield
3	783-05006	Lower Heat Shield
4	710-0227	Screw, #8-18 x .50
5	710-0599	Screw, 1/4-20, 0.500
6	710-0642	Screw, 1/4-20, 0.750
7	710-1237	Screw, #10-32, .625
8	710-1314A	Socket Cap Screw, 5/16-18, .625
9	710-1315	Self-tapping Screw, 3/8-16, 1.25
10	712-0271	Hex Sems Nut, 1/4-20
11	721-0208	Exhaust Gasket
12	725-0157	Cable Tie, 7.4"
13	726-0205	Hose Clamp, .490
14	728-04000	Pop Rivet .188 x .325
15	731-1682A	Oil Drain Sleeve
16	751B221535	Casing Clamp
17	751-0564B	Muffler Deflector
18	751-10013	Exhaust Pipe
19	751-10162	Muffler, Single Inlet
20	751-10349	Fuel Line Hose
21	751-10353	Long Muffler Deflector
22	783-04573	LH Muffler Bracket
23	783-04574	RH Muffler Bracket

## **NOTES:**

*Use this page to make notes and write down important information.*



*For parts and/or accessories  
please call  
1-866-840-6483, or  
1-330-558-7220.  
[www.troybilt.com](http://www.troybilt.com)*

## NOTES:

*Use this page to make notes and write down important information.*



*For parts and/or accessories  
please call  
1-866-840-6483, or  
1-330-558-7220.*

[www.troybilt.com](http://www.troybilt.com)

## NOTES:

*Use this page to make notes and write down important information.*



*For parts and/or accessories please call 1-866-840-6483, or 1-330-558-7220.  
www.troybilt.com*

---

**CALIFORNIA EMISSION CONTROL WARRANTY STATEMENT  
YOUR WARRANTY RIGHTS AND OBLIGATIONS**

The California Air Resources Board and MTD Consumer Group Inc are pleased to explain the evaporative emission control system warranty on your 2006 lawn mower. In California, new lawn mower must be designed, built and equipped to meet the State's stringent anti-smog standards. MTD Consumer Group Inc must warrant the EECS on your lawn mower for the period of time listed below provided there has been no abuse, neglect or improper maintenance of your lawn mower.

Your EECS may include parts such as the carburetor, fuel-injection system, the ignition system, catalytic converter, fuel tanks, fuel lines, fuel caps, valves, canisters, filters, vapor hoses, clamps, connectors, and other associated emission-related components.

**Where a warrantable condition exists, MTD Consumer Group Inc will repair your lawn mower at no cost to you including diagnosis, parts and labor.**

**MANUFACTURER'S WARRANTY COVERAGE:**

This evaporative emission control system is warranted for two years. If any evaporative emission-related part on your equipment is defective, the part will be repaired or replaced by MTD Consumer Group Inc.

**OWNER'S WARRANTY RESPONSIBILITIES:**

As the lawn mower owner, you are responsible for performance of the required maintenance listed in your owner's manual. MTD Consumer Group Inc recommends that you retain all receipts covering maintenance on your lawn mower, but MTD Consumer Group Inc cannot deny warranty solely for the lack of receipts.

As the lawn mower owner, you should however be aware that MTD Consumer Group Inc may deny you warranty coverage if your lawn mower or a part has failed due to abuse, neglect, or improper maintenance or unapproved modifications.

You are responsible for presenting your lawn mower to MTD Consumer Group Inc's distribution center or service center as soon as the problem exists. The warranty repairs should be completed in a reasonable amount of time, not to exceed 30 days. If you have a question regarding your warranty coverage, you should contact the MTD Consumer Group Inc Service Department at 1-800-800-7310.

**GENERAL EMISSIONS WARRANTY COVERAGE:**

MTD Consumer Group Inc warrants to the ultimate purchaser and each subsequent purchaser that the lawn mower is: Designed, built and equipped so as to conform with all applicable regulations; and free from defects in materials and workmanship that cause the failure of a warranted part to be identical in all material respects to that part as described in MTD Consumer Group Inc's application for certification.

The warranty period begins on the date the lawn mower is delivered to an ultimate purchaser or first placed into service. The warranty period is two years.

Subject to certain conditions and exclusions as stated below, the warranty on emission-related parts is as follows:

1. Any warranted part that is not scheduled for replacement as required maintenance in the written instructions supplied, is warranted for the warranty period stated above. If the part fails during the period of warranty coverage, the part will be repaired or replaced by MTD Consumer Group Inc according to subsection (4) below. Any such part repaired or replaced under warranty will be warranted for the remainder of the period.
2. Any warranted part that is scheduled only for regular inspection in the written instructions supplied is warranted for the warranty period stated above. Any such part repaired or replaced under warranty will be warranted for the remaining warranty period.
3. Any warranted part that is scheduled for replacement as required maintenance in the written instructions supplied is warranted for the period of time before the first scheduled replacement date for that part. If the part fails before the first scheduled replacement, the part will be repaired or replaced by MTD Consumer Group Inc according to subsection (4) below. Any such part repaired or replaced under warranty will be warranted for the remainder of the period prior to the first scheduled replacement point for the part.
4. Repair or replacement of any warranted part under the warranty provisions herein must be performed at a warranty station at no charge to the owner.
5. Notwithstanding the provisions herein, warranty services or repairs will be provided at all of our distribution centers that are franchised to service the subject engines or equipment.
6. The lawn mower owner will not be charged for diagnostic labor that is directly associated with diagnosis of a defective, emission-related warranted part, provided that such diagnostic work is performed at a warranty station.
7. MTD Consumer Group Inc is liable for damages to other engine or equipment components proximately caused by a failure under warranty of any warranted part.
8. Throughout the lawn mower warranty period stated above, MTD Consumer Group Inc will maintain a supply of warranted parts sufficient to meet the expected demand for such parts.
9. Any replacement part may be used in the performance of any warranty maintenance or repairs and must be provided without charge to the owner. Such use will not reduce the warranty obligations of MTD Consumer Group Inc.
10. Add-on or modified parts that are not exempted by the Air Resources Board may not be used. The use of any non-exempted add-on or modified parts by the ultimate purchaser will be grounds for disallowing a warranty claims. MTD Consumer Group Inc will not be liable to warrant failures of warranted parts caused by the use of a non-exempted add-on or modified part.

**WARRANTED PARTS:**

The repair or replacement of any warranted part otherwise eligible for warranty coverage may be excluded from such warranty coverage if MTD Consumer Group Inc demonstrates that the lawn mower has been abused, neglected, or improperly maintained, and that such abuse, neglect, or improper maintenance was the direct cause of the need for repair or replacement of the part. That notwithstanding, any adjustment of a component that has a factory installed, and properly operating, adjustment limiting device is still eligible for warranty coverage. The following emission warranty parts list are covered: Fuel Line, Fuel Line Clamps

---

# MANUFACTURER'S LIMITED WARRANTY FOR



The limited warranty set forth below is given by Troy-Bilt LLC with respect to new merchandise purchased and used in the United States, its possessions and territories.

"Troy-Bilt" warrants this product against defects in material and workmanship for a period of two (2) years commencing on the date of original purchase and will, at its option, repair or replace, free of charge, any part found to be defective in materials or workmanship. This limited warranty shall only apply if this product has been operated and maintained in accordance with the Operator's Manual furnished with the product, and has not been subject to misuse, abuse, commercial use, neglect, accident, improper maintenance, alteration, vandalism, theft, fire, water, or damage because of other peril or natural disaster. Damage resulting from the installation or use of any part, accessory or attachment not approved by Troy-Bilt for use with the product(s) covered by this manual will void your warranty as to any resulting damage.

Normal wear parts are warranted to be free from defects in material and workmanship for a period of thirty (30) days from the date of purchase. Normal wear parts include, but are not limited to items such as: batteries, belts, blades, blade adapters, grass bags, rider deck wheels, seats, snow thrower skid shoes, shave plates, auger spiral rubber and tires.

**HOW TO OBTAIN SERVICE:** Warranty service is available, WITH PROOF OF PURCHASE, through your local authorized service dealer. To locate the dealer in your area, check your Yellow Pages, or contact Troy-Bilt LLC at P.O. Box 361131, Cleveland, Ohio 44136-0019, or call 1-866-840-6483 or 1-330-558-7220, or log on to our Web site at [www.troybilt.com](http://www.troybilt.com).

This limited warranty does **not** provide coverage in the following cases:

- a. The engine or component parts thereof. These items may carry a separate manufacturer's warranty. Refer to applicable manufacturer's warranty for terms and conditions.
- b. Log splitter pumps, valves, and cylinders have a separate one year warranty.
- c. Routine maintenance items such as lubricants, filters, blade sharpening, tune-ups, brake adjustments, clutch adjustments, deck adjustments, and normal deterioration of the exterior finish due to use or exposure.
- d. Service completed by someone other than an authorized service dealer.

- e. Troy-Bilt does not extend any warranty for products sold or exported outside of the United States, its possessions and territories, except those sold through Troy-Bilt's authorized channels of export distribution.
- f. Replacement parts that are not genuine Troy-Bilt parts.
- g. Transportation charges and service calls.

**No implied warranty, including any implied warranty of merchantability of fitness for a particular purpose, applies after the applicable period of express written warranty above as to the parts as identified. No other express warranty, whether written or oral, except as mentioned above, given by any person or entity, including a dealer or retailer, with respect to any product, shall bind Troy-Bilt. During the period of the warranty, the exclusive remedy is repair or replacement of the product as set forth above.**

**The provisions as set forth in this warranty provide the sole and exclusive remedy arising from the sale. Troy-Bilt shall not be liable for incidental or consequential loss or damage including, without limitation, expenses incurred for substitute or replacement lawn care services or for rental expenses to temporarily replace a warranted product.**

Some states do not allow the exclusion or limitation of incidental or consequential damages, or limitations on how long an implied warranty lasts, so the above exclusions or limitations may not apply to you.

In no event shall recovery of any kind be greater than the amount of the purchase price of the product sold. **Alteration of safety features of the product shall void this warranty.** You assume the risk and liability for loss, damage, or injury to you and your property and/or to others and their property arising out of the misuse or inability to use the product.

This limited warranty shall not extend to anyone other than the original purchaser or to the person for whom it was purchased as a gift.

**HOW STATE LAW RELATES TO THIS WARRANTY:** This limited warranty gives you specific legal rights, and you may also have other rights which vary from state to state.

**IMPORTANT:** Owner must present Original Proof of Purchase to obtain warranty coverage.